

CASTECH[®]
福晶科技



OPTICS CATALOGUE

(2018-2019)



福建福晶科技股份有限公司
CASTECH INC.

公司简介 INTRODUCTION



After near 30 years rapid growth since the foundation in 1988, CASTECH INC.(CASTECH) has become a recognized leading supplier of crystals, precision optics and laser components in the world. In 2008 CASTECH successfully completed IPO in China Shenzhen Stock Exchange (SSE:002222).

In order to meet the growing demand of optics industry, CASTECH devoted to continuously developing its capability of delivering one-stop solution to customers. We utilized different manufacturing processes including conventional, CNC, double-side, CP polishing and thin film coating with IBS, IAD, EB technique in our new 430,000 square feet modern facility. Combined with professional staff and top level management, CASTECH is proud of its excellent performance in either prototype or high-volume production of standard and OEM optics.

CASTECH involves a wide range of high precision spherical, cylindrical and flat optics components into its portfolio. We are flexible in customized products and features in high surface accuracy up to 1/20 wave, surface quality up to 10-5 scratch/dig, and low surface roughness up to 2 angstrom. We are also well experienced in the high laser damage threshold coating by our unique proprietary technology.

CASTECH recognizes the most importance of quality control. We set up a complete quality system ISO 9001:2000 certified and invested in advanced metrology instruments including Zygo Interferometers, Perkin-Elmer Lambda 950 spectrometer, Nikon Microscope, Photo-Thermal Common-Path Interferometer, Prism Master C200, High Precision Transmission and Reflection Meter, and Ellipsometers, These equipments along with many others, ensure that we comply with all tight specifications for our products.

Our mission is to deliver the best products and solutions to our customers in photonics industry, and help them to realize their full potential in business. Here at CASTECH, we value comity, integrity, honesty, and innovation.



CASTECH has built the completed state-of-art optics production line in house integrating different processing technologies to feature in both high accuracy and high efficiency.



The measurement capability determines the extreme limit of accuracy you can get. That's why we keep investing considerably on advanced metrology instruments to guarantee every specification of our products under real precise control.

- | | |
|------------------------------------|---|
| 1、Zygo New View 8300 profilometer | 2、Zygo GPI-XP 4" interferometer |
| 3、Zygo GPI-XP interferometer | 4、JAW M2000 Ellipsometer |
| 5、Trioptics PrismaStar Goniometer | 6、Trioptics Spheroconpact |
| 7、Trioptics Optomatic2000 | 8、Perkin-Elmer FT-IR Spectrometer |
| 9、Zeiss AX10 microscope | 10、Olympus Microscope |
| 11、Hinds PER/ER Measurement System | 12、Perkin-Elmer Lambda 950 Spectrometer |

CONTENTS

Antireflective Coatings



- | | |
|--|---|
| 1. Single layer MgF_2 Coating | 2 |
| 2. V-type Antierflective Coatings | 2 |
| 3. Double-V and Triple-V Antireflective Coatings | 3 |
| 4. Broadband Antireflective Coatings | 3 |

Windows



- | | |
|------------------------|---|
| 1. Parallel Windows | 4 |
| 2. Rectangular Windows | 5 |
| 3. Square Windows | 6 |
| 4. Brewster Windows | 7 |

Mirrors



Coating guide

- | | |
|-----------------------------------|----|
| 1. Broadband Metallic Coatings | 8 |
| 2. Broadband Dielectric Coatings | 9 |
| 3. Laser Line Dielectric Coatings | 10 |

Substrate

- | | |
|------------------------|----|
| 1. Parallel Mirrors | 11 |
| 2. Rectangular Mirrors | 12 |
| 3. Square Mirrors | 13 |

Prisms

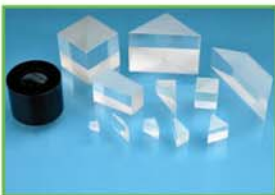

- | | |
|----------------------------------|----|
| 1. Right Angle Prisms | 14 |
| 2. Penta Prisms | 16 |
| 3. Dove Prisms | 17 |
| 4. Roof Prisms | 18 |
| 5. Porro Prisms | 19 |
| 6. Retro-Reflector | 20 |
| 7. Anamorphic Prism Pairs | 21 |
| 8. Pellin Broca Prisms | 22 |
| 9. Equilateral Dispersive Prisms | 23 |

Lenses

Spherical Lenses

- | | |
|-------------------------|----|
| 1. Plano-Convex Lenses | 24 |
| 2. Plano-Concave Lenses | 27 |
| 3. Bi-Convex Lenses | 29 |

CONTENTS

Lenses



- | | |
|-----------------------------|----|
| 4. Bi-Concave Lenses | 31 |
| 5. Meniscus Lenses | 33 |
| 6. Negative Meniscus Lenses | 34 |

Cylindrical Lenses

- | | |
|-------------------------------------|----|
| 7. Plano-convex Cylindrical Lenses | 35 |
| 8. Plano-concave Cylindrical Lenses | 36 |

Waveplates



- | | |
|--|----|
| 1. Multi-Order Waveplates | 39 |
| 2. Optically Contacted Zero-Order Waveplates | 41 |
| 3. Air Spaced Zero-Order waveplates | 42 |
| 4. True Cemented Zero-Order Waveplates | 43 |
| 5. True Zero-Order Waveplates | 44 |
| 6. Achromatic Zero-Order Waveplates | 45 |
| 7. Telecom Waveplates | 47 |
| 8. Mounts and Holders for Waveplates | 48 |

Polarizers



- | | |
|--------------------------|----|
| 1. Polarization Rotators | 49 |
|--------------------------|----|

Birefringent Polarizers

- | | |
|-----------------------------|----|
| 2. Glan-Taylor Polarizers | 50 |
| 3. Glan-Laser Polarizers | 51 |
| 4. Glan-Thompson Polarizers | 52 |
| 5. Wollaston Polarizers | 53 |
| 6. Rochon Polarizers | 54 |

Polarizing Beamsplitter Cubes

- | | |
|--|----|
| 7. Broadband Polarizing Beamsplitter Cube | 55 |
| 8. UV Laser Line Polarizing Beamsplitter Cubes | 56 |
| 9. Laser Line Polarizing Beamsplitter Cubes | 57 |

Beamsplitters



- | | |
|---|----|
| 1. Broadband Dielectric Beamsplitters | 58 |
| 2. Laser Line Non-Polarizing Beamsplitters | 59 |
| 3. Broadband Non-Polarizing Beamsplitter Cubes | 60 |
| 4. UV Non-Polarizing Beamsplitter Cubes | 61 |
| 5. Laser Line Non-Polarizing Beamsplitter Cubes | 62 |

CASTECH has strong capability in fabricating optical components with various optical material. The most important material properties to consider for an optical element are transmission versus wavelength, index of refraction, thermal characteristics, mechanical and chemical characteristics and cost.

There are two instances in which you might need to know more about optical material. First, you may need to determine the performance of a catalog component in a particular application. Second, you may need specific information when selecting the material for a custom component. The data in the following is intended to assist in these situations.

To select the right material seems overwhelming. The simplest way is to let CASTECH know your applications, and we select them for you.

Standard Material that CASTECH uses include

Optical glass:	UV Fused Silica; N-BK7; Borofloat; SF2; N-SF5...
Optical crystal:	CaF ₂ ; Silicon; Ge; ZnSe; ZnS; YAG...
Birefringence material:	MgF ₂ ; YVO ₄ ; Quartz; Calcite; α-BBO; Sapphire ...

Material	Refractive Index	Transmission Range (um)	Thermal Expansion Coefficient (10 ⁻⁶ /K)
UV Fused Silica	1.4858@308nm	0.185-2.5	0.5
N-BK7	1.5164@588nm	0.330-2.1	7.1
Borofloat	1.47311@546.1nm	0.32-2.8	3.25
SF2	1.64379@633nm	0.36-2.5	8.4
N-SF5	1.66848@633nm	0.40-2.5	7.9
MgF ₂	no=1.3836;ne=1.3957@405nm	0.130-7.0	8.8 c; 13.1 a
YVO ₄	no=1.9500;ne=2.1554@1.3um	0.400-5.0	11.37 c; 4.43 a
Quartz	no=1.5427;ne=1.5518@633nm	0.200-2.3	6.88 c; 12.38 a
Calcite	no=1.6557;ne=1.4852@633nm	0.350-2.3	5.68 c; 24.39 a
α-BBO	no=1.6749;ne=1.5555@532nm	0.190-3.5	33.3 c; 0.5 a
Sapphire	1.755@1.0um	0.180-4.5	8.4
CaF ₂	1.399@5.0um	0.170-7.8	18.85
Silicon	3.4179@10um	1.00-7.0	2.23
Ge	4.003@10um	2.00-23	5.7
ZnSe	2.400@10.6um	0.5-22	7.6
Silicon	3.416@10.6um	1.5-7	4.5

Antireflective Coatings

1. Single Layer MgF₂ Coating

- **Wavelength Range: 400-700 nm**
- **R<0.25% over wide ranges on sapphire, Nd:YAG, and high index glass.**

Magnesium fluoride is probably the most widely used thin film material for optical coating. Its performance is not outstanding but represents a significant improvement over an uncoated surface. Because its index is too low to provide a good impedance match at the air-glass interface.

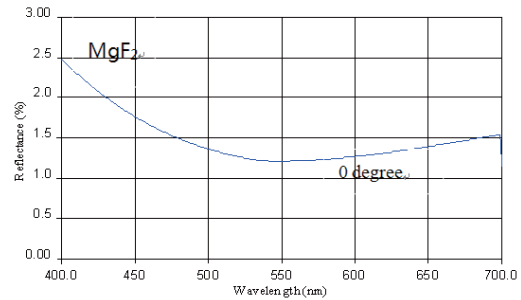

Coating Code: -MF

Note: When ordering, be sure to specify substrate material, angle of incidence.

2. V-type Antireflection Coatings

CASTECH offers a full range of V-Coating from 250nm to 3000 nm. This type of coating can attain the lowest reflectivity at the center wavelength, which can be adjusted to your required wavelength and angle.

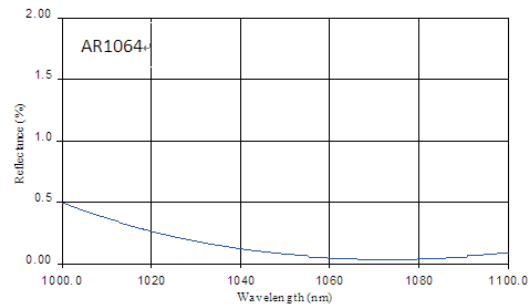
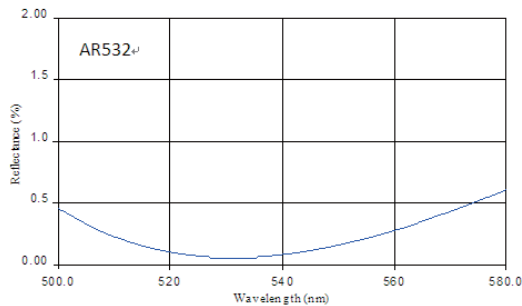

Substrate Material	BK7 ; UV fused silica etc.		
Damage Threshold	2000W/cm ² 3J/cm ² with 10nsec pulses @each wavelength		
Coating Code	Wavelength (nm)	Angle of incidence	Reflectivity per Surface
AR488	488-514.5	0-15°	R _{max} <0.25%
AR532	532	0-15°	R _{max} <0.25%
AR633	632.8	0-15°	R _{max} <0.25%
AR694	694	0-15°	R _{max} <0.25%
AR1064	1064	0-15°	R _{max} <0.25%

3. Double-V and Triple-V AR

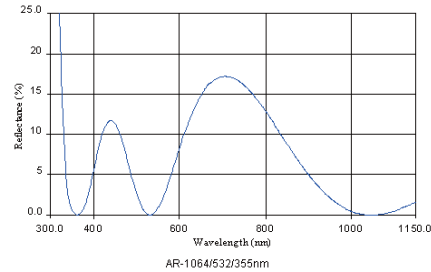
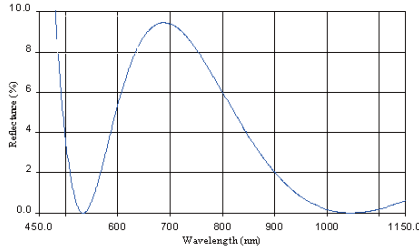

Double-V:

- $R < 0.3\%$ @ 1064nm, 0° incidence
- $R < 0.6\%$ @ 532nm, 0° incidence
- Damage Threshold for Double-V
 - 5 J/cm² @ 532nm
 - 10 J/cm² @ 1064nm

Triple-V:

- $R < 0.3\%$ @ 1064nm, 0° incidence
- $R < 0.6\%$ @ 532nm, 0° incidence
- $R < 1.5\%$ @ 355nm, 0° incidence

4. Broadband Antireflection Coatings

Different from single layer MgF₂ coating, the multilayer antireflective coatings can reach higher transmission for broadband spectrum. Therefore, it is the ideal for a wide range of multi-wavelength laser and white light application. Please notify that the wavelength range and reflectivity of the coating are obviously changed according to the incident angle.

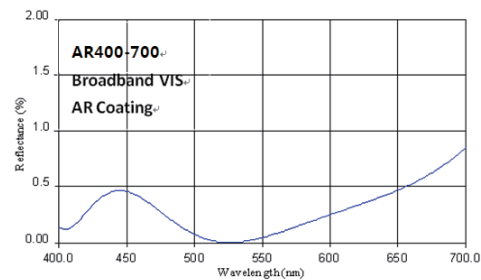
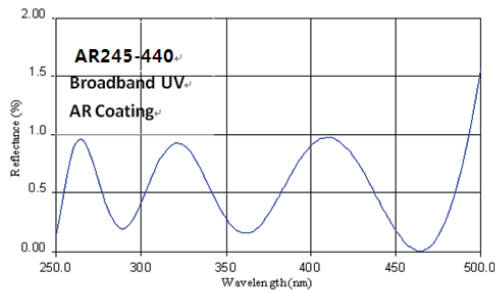

- AR650-1000, AR1000-1550 please see Page 26

Substrate Material	BK7, UV fused silica, etc.			
Coating Code	Wavelength (nm)	Angle of incidence	Reflectivity per Surface	Damage Threshold
AR245-440	245-440 (UV band)	0-15°	$R_{avg} < 0.5\%$, $R_{max} < 1.0\%$	500W/cm ² 1J/cm ² with 10nsec pulses @325nm, typical
AR400-700	400-700 (VIS band)	0-15°	$R_{avg} < 0.5\%$, $R_{max} < 1.5\%$	1000W/cm ² 2J/cm ² with 10nsec pulses @532nm, typical
AR650-1000	650-1000 (NIR band)	0-15°	$R_{avg} < 0.5\%$, $R_{max} < 1.5\%$	1000W/cm ² 2J/cm ² with 10nsec pulses @1064nm, typical
AR1000-1550	1000-1550 (IR band)	0-15°	$R_{avg} < 0.5\%$, $R_{max} < 1.5\%$	1000W/cm ² 2J/cm ² with 10nsec pulses @1064nm, typical

Parallel Windows

Specifications

Material:	BK7 or UV fused silica
Diameter Tolerance:	+0.0/-0.15mm
Thickness Tolerance:	±0.25mm
Parallelism:	<5"
Surface Quality:	20/10 scratch / dig
Transmitted Wavefront:	$\lambda / 10$ @632.8nm
Clear Aperture:	Central 85% of diameter
Chamfers:	12.7&25.4mm:0.25-0.75mm face width x 45° +/-15° 50.8mm :0.38-1.14 mm face width x 45° +/-15°

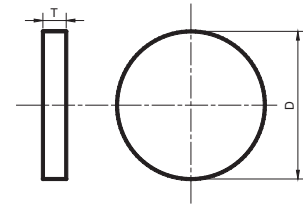

- Most sizes with $\lambda / 20$ transmitted wavefront and 10-5 surface quality are available
- All kinds of coatings are available, see page 2 - 3
- Custom designs for other sizes and coatings are also available upon request

Order Information

WIN	—	127	—	060	—	BK7
Product Code		Dia=12.7 mm		Thickness=6.0mm		Material

Parallel Windows

Part Number	Diameter D (mm)	Thickness T (mm)	Material	Surface Quality	Transmitted Wavefront
WIN-127-031-BK7	12.7	3.175	BK7	20/10	$\lambda / 10$
WIN-127-060-BK7	12.7	6.0	BK7	20/10	$\lambda / 10$
WIN-254-060-BK7	25.4	6.0	BK7	20/10	$\lambda / 10$
WIN-254-063-BK7	25.4	6.35	BK7	20/10	$\lambda / 10$
WIN-508-100-BK7	50.8	10.0	BK7	20/10	$\lambda / 10$
WIN-127-031-UVFS	12.7	3.175	UVFS	20/10	$\lambda / 10$
WIN-127-060-UVFS	12.7	6.0	UVFS	20/10	$\lambda / 10$
WIN-254-060-UVFS	25.4	6.0	UVFS	20/10	$\lambda / 10$
WIN-254-063-UVFS	25.4	6.35	UVFS	20/10	$\lambda / 10$
WIN-508-100-UVFS	50.8	10.0	UVFS	20/10	$\lambda / 10$

Rectangular Windows

Specifications

Material:	BK7 or UV fused silica
Diameter Tolerance:	+0.0/-0.15mm
Thickness Tolerance:	±0.25mm
Parallelism:	<5"
Surface Quality:	20/10 scratch / dig
Transmitted Wavefront:	$\lambda / 10 @632.8\text{nm}$
Clear Aperture:	Central 85% of diameter
Chamfers:	12.7&25.4mm:0.25-0.75mm face width x 45° +/-15° 50.8mm :0.38-1.14 mm face width x 45° +/-15°

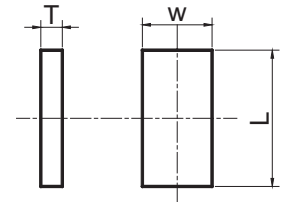

- Most sizes $\lambda / 20$ transmitted wavefront, 10-5 surface quality are available
- All kinds of coatings are available, see page 2-3
- Custom designs for other sizes and coatings are also available upon request

Order Information:

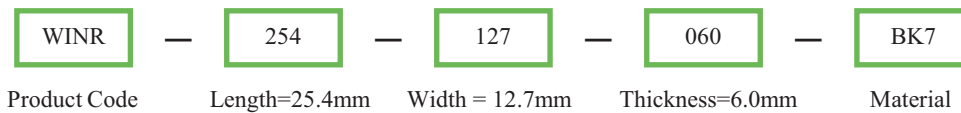

Square Windows

Part Number	Length L (mm)	Width W (mm)	Thickness T (mm)	Material	Surface Quality	Transmitted Wavefront
WINR-127-063-060-BK7	12.7	6.35	3.175	BK7	20-10	$\lambda / 10$
WINR-254-127-063-BK7	25.4	12.7	6.35	BK7	20-10	$\lambda / 10$
WINR-127-063-031-UVFS	12.7	6.35	3.175	UVFS	20-10	$\lambda / 10$
WINR-127-063-063-UVFS	12.7	6.35	6.35	UVFS	20-10	$\lambda / 10$
WINR-254-127-063-UVFS	25.4	12.7	6.35	UVFS	20-10	$\lambda / 10$
WINR-508-254-100-UVFS	50.8	25.4	6.35	UVFS	20-10	$\lambda / 10$

Square Windows

Specifications

Material:	BK7 or UV fused silica
Diameter Tolerance:	+0.0/-0.15mm
Thickness Tolerance:	±0.25mm
Parallelism:	<5"
Surface Quality:	20/10 scratch / dig
Transmitted Wavefront:	$\lambda / 10 @ 632.8\text{nm}$
Clear Aperture:	Central 85% of diameter
Chamfers:	12.7&25.4mm:0.25-0.75mm face width x 45° +/-15° 50.8mm :0.38-1.14 mm face width x 45° +/-15°

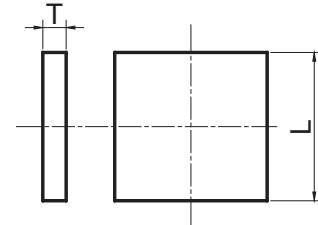

- Most sizes $\lambda / 20$ transmitted wavefront, 10-5 surface quality are available
- All kinds of coatings are available, see page 2-3
- Custom designs for other sizes and coatings are also available upon request

Order Information

WINS	—	127	—	060	—	BK7
Product Code		Length=12.7mm		Thickness=6.0mm		Material

Square Windows

Part number	Length L (mm)	Thickness T (mm)	Material	Surface Quality	Transmitted Wavefront
WINS-127-031-BK7	12.7	3.175	BK7	20-10	$\lambda / 10$
WINS-254-063-BK7	25.4	6.35	BK7	20-10	$\lambda / 10$
WINS-127-063-UVFS	12.7	6.35	UVFS	20-10	$\lambda / 10$
WINS-254-063-UVFS	25.4	6.35	UVFS	20-10	$\lambda / 10$
WINS-508-063-UVFS	50.8	6.35	UVFS	20-10	$\lambda / 10$

- Other sizes and surface quality are upon customers' request

Brewster Windows

Specifications

Material:	BK7 or UV fused silica
Diameter Tolerance:	+0.0/-0.15mm
Thickness Tolerance:	±0.25mm
Parallelism:	<5"
Brewster Angle (θ):	56.6° for BK7 at 588nm 56.1° for UVFS at 308nm
Surface Quality:	20/10 scratch/dig
Transmitted Wavefront:	λ/10@632.8nm
Clear Aperture:	Central 85% of diameter
Chamfers:	<0.35mm face width × 45° typical

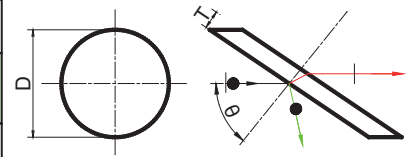

- Most sizes λ/20 transmitted wavefront, 10-5 surface quality
- All kinds of coatings are available, see page 2-3
- Custom designs for other sizes and coatings are also available upon request

Order Information

WINB	—	100	—	020	—	BK7
Product Code		Dia=10.0 mm		Thickness=2.0mm		Material

Brewster Windows

Part Number	Diameter D (mm)	Thickness T (mm)	Material	Surface Quality	Transmitted Wavefront
WINB-080-020-BK7	8	2.0	BK7	20/10	λ/10
WINB-100-020-BK7	10	2.0	BK7	20/10	λ/10
WINB-160-020-BK7	16	2.0	BK7	20/10	λ/10
WINB-254-020-BK7	25.4	2.0	BK7	20/10	λ/10
WINB-060-020-UVFS	6	2.0	UVFS	20/10	λ/10
WINB-080-020-UVFS	8	2.0	UVFS	20/10	λ/10
WINB-100-020-UVFS	10	2.0	UVFS	20/10	λ/10
WINB-160-030-UVFS	16	3.0	UVFS	20/10	λ/10
WINB-254-030-UVFS	25.4	3.0	UVFS	20/10	λ/10

Broadband Metallic Coatings

Metallic mirrors are excellent broadband reflectors. CASTECH offers four standard coatings, covering the UV, visible and IR. These mirrors are available in round sizes from dia12.7-50.8mm with BK7 or BOROFLOAT.



Order Information

To order append the coating code PS to the substrate number.
For example MIR-127-031-BK7-PS

Substrate Material	BK7 or BOROFLOAT		
Damage Threshold	UVEA:100W/cm ² 0.3J/cm ² with 10 nsec pulses @308nm,typical EA: 100W/cm ² 0.3J/cm ² with 10 nsec pulses @532nm,typical PS:1000W/cm ² 1J/cm ² with 10 nsec pulses @1064nm,typical PG:200W/cm ² 1J/cm ² with 10 nsec pulses @1064nm,typical		
Coating Code	Wavelength Range (nm)	Reflectivity per Surface	Coating Type
UVEA	250-600 nm	Ravg>90%	UV Enhanced Aluminum
EA	450-700 nm	Ravg>93% ,Rmin>90%	Enhanced Aluminum
PS	480-1100 nm 1.1-20 um	Ravg>96% ,Rmin>93% Ravg>98.5% ,Rmin>97%	Protected Silver
PG	650-1700 nm 1.7-20 um	Ravg>96% ,Rmin>93% Ravg>98% ,Ravg>96%	Protected Gold

- Custom designs for other coatings are available upon request.

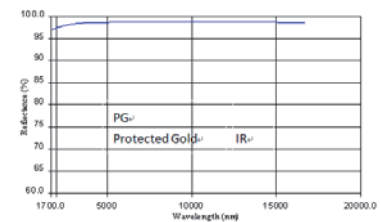
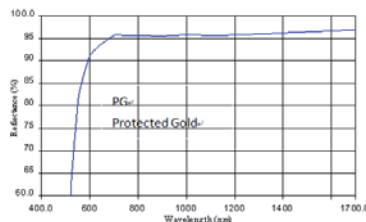
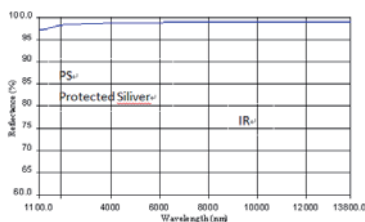
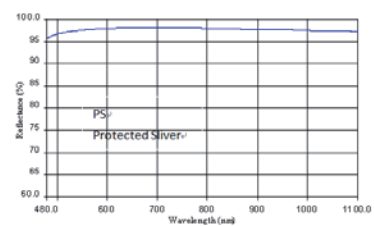
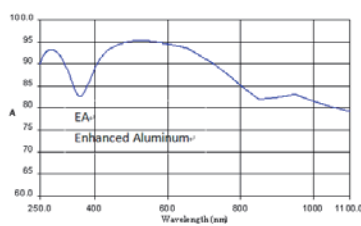
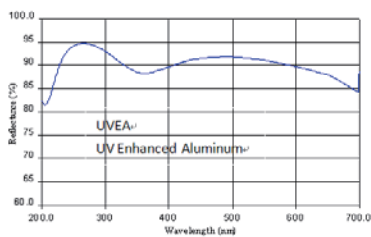

Broadband Dielectric Coatings



- High quality ,excellent value
- Broaband dielectric coatings
- Hight damage threshrod

CASTECH offers two standard dielectric broadband coatings . Other coatings are available upon request.

Specifications

Substrate Material	BK7 or BOROFLOAT		
Damage Threshold	BD1:500W/cm ² 1J/cm ² with 10 nsec pulses within the wavelength range typical BD2: 1000W/cm ² 2J/cm ² with 10 nsec pulses within the wavelength range typical		
Coating Code	Wavelength Range (nm)	Reflectivity per Surface	Angle of incidence
BD488-694	488-694 nm (VIS band)	R _s ,R _p >99%	0-45°
BD700-950	700-950 nm (NIR band)	R _s >99% ,R _p >98%@700-950 nm R _{avg} >80%@632.8 nm	0-45°

Order Information

To order append the coating code BD488-694 to the substrate number.
For example MIR-127-031-BK7-BD488-694

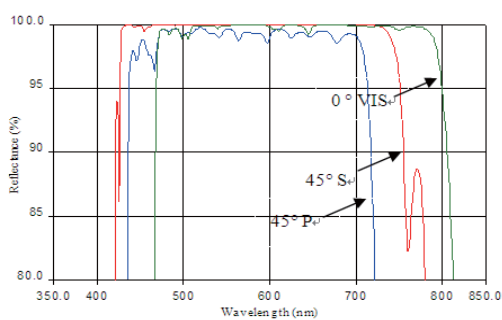

BD488-694

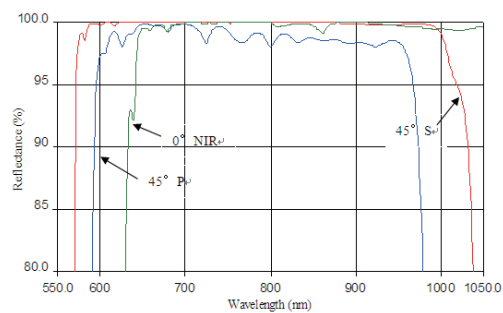

BD700-950

Laser Line Dielectric Coatings



- High efficiency narrowband reflectivity
- $R_s, R_p > 99\%$ at laser line
- High damage threshold

These coatings are highly efficient reflectors optimized for a narrow wavelength range. CASTECH offers eight standard dielectric coatings with substrates.

Specifications

Coating Code	Center Wavelength (nm)	Angle of incidence	Reflectivity per Surface	Damage Threshold
DM325	325	0-45°	$R_s, R_p > 99\%$	1000W/cm ² 2J/cm ²
DM441	441.8	0-45°	$R_s, R_p > 99\%$	500W/cm ² 1J/cm ²
DM488	488-514.5	0-45°	$R_s, R_p > 99\%$	500W/cm ² 1J/cm ²
DM532	532	0-45°	$R_s, R_p > 99\%$	500W/cm ² 2J/cm ²
DM633	632.8	0-45°	$R_s, R_p > 99\%$	500W/cm ² 1J/cm ²
DM1064	1064	0-45°	$R_s, R_p > 99\%$	500W/cm ² 2J/cm ²
DM1300	1300	0-45°	$R_s, R_p > 99\%$	500W/cm ² 1J/cm ²
DM1550	1550	0-45°	$R_s, R_p > 99\%$	500W/cm ² 2J/cm ²

Order Information

To order append the coating code to the substrate number.
For example MIR-127-031-BK7-DM532

- Custom designs for other coatings are available upon request .

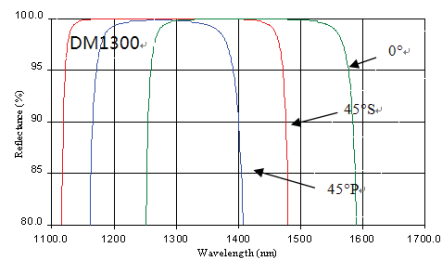
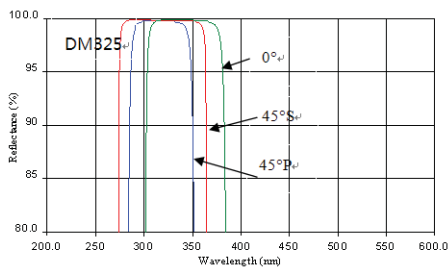
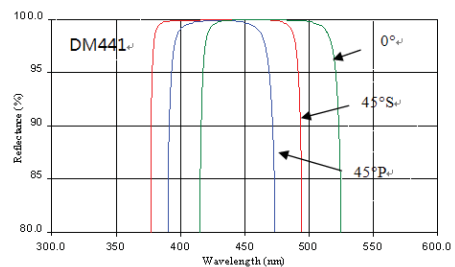

Parallel Mirrors

Specifications

Material:	BK7 or BOROFLOAT
Diameter Tolerance:	+0.0/-0.15mm
Thickness Tolerance	±0.25mm
Parallelism:	<30"
S1 Surface Quality :	See Order Infor Table
S1 Surface Flatness :	See Order Infor Table
Clear Aperture:	Central 80% of diameter
S2 surface :	Ground
Chamfers:	12.7&25.4mm:0.25-0.75mm face width x 45° +/-15° 50.8mm :0.38-1.14 mm face width x 45° +/-15°

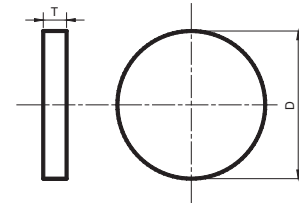

Order Information

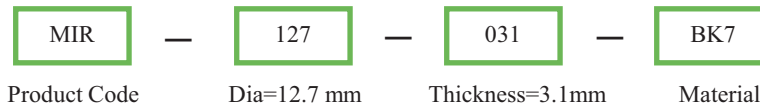

Part Number	Diameter D (mm)	Thickness T (mm)	Material	Surface Quality	Surface Flatness
MIR-127-031-BK7	12.7	3.1	BK7	20-10	λ/8
MIR-190-045-BK7	19.05	4.57	BK7	20-10	λ/8
MIR-254-060-BK7	25.4	6.0	BK7	20-10	λ/8
MIR-127-031-BOROFLOAT	12.7	3.1	BOROFLOAT	20-10	λ/8
MIR-190-045-BOROFLOAT	19.05	4.57	BOROFLOAT	20-10	λ/8
MIR-254-060-BOROFLOAT	25.4	6.0	BOROFLOAT	20-10	λ/8

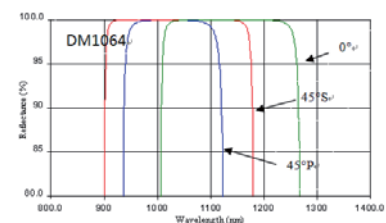
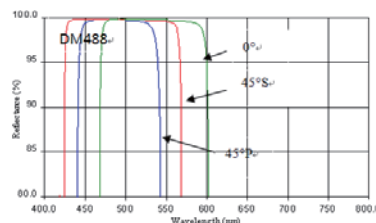
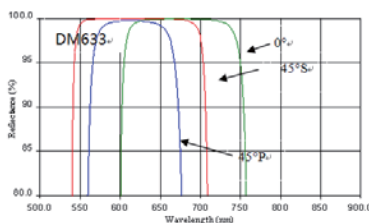

Rectangular Mirrors

Specifications

Material:	BK7 or BOROFLOAT
Diameter Tolerance:	+0.0/-0.15mm
Thickness Tolerance	±0.25mm
Parallelism:	<30"
S1 Surface Quality :	See Order Infor Table
S1 Surface Flatness :	See Order Infor Table
Clear Aperture:	Central 80% of diameter
S2 surface :	Ground
Chamfers:	0.25-0.75mm face width x 45° +/-15°

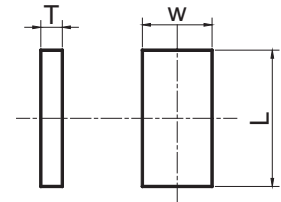

Order Information

MIRR	—	254	—	127	—	060	—	BK7
Product Code		Length=25.4 mm		Width=12.7mm		Thickness=6.0mm		Material

Rectangular Mirrors

Part Number	Length L (mm)	Width W (mm)	Thickness T (mm)	Material	Surface Quality	Surface Flatness
MIRR-127-063-031-BK7	12.7	6.35	3.175	BK7	20-10	λ / 4
MIRR-254-127-063-BK7	25.4	12.7	6.35	BK7	20-10	λ / 4
MIRR-127-063-031- BOROFLOAT	12.7	6.35	3.175	BOROFLOAT	20-10	λ / 4
MIRR-127-063-063- BOROFLOAT	12.7	6.35	6.35	BOROFLOAT	20-10	λ / 4
MIRR-254-127-063- BOROFLOAT	25.4	12.7	6.35	BOROFLOAT	20-10	λ / 4

Square Mirrors

Specifications

Material:	BK7 or BOROFLOAT
Diameter Tolerance:	+0.0/-0.15mm
Thickness Tolerance:	±0.25mm
Parallelism:	<30"
S1 Surface Quality:	See Order Infor Table
S1 Surface Flatness:	See Order Infor Table
Clear Aperture:	Central 80% of diameter
S2 surface:	Ground
Chamfers:	0.25-0.75mm face width x 45° +/-15°

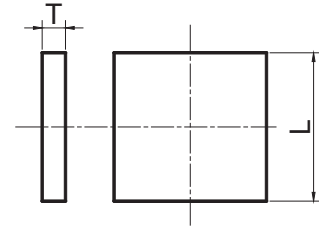

Order Information

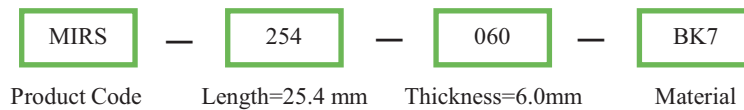

Square Mirrors

Part Number	Length L (mm)	Thickness T (mm)	Material	Surface Quality	Surface Flatness
MIRS-127-031-BK7	12.7	3.175	BK7	20-10	λ / 4
MIRS-254-063-BK7	25.4	6.35	BK7	20-10	λ / 4
MIRS-127-031- BOROFLOAT	12.7	3.175	BOROFLOAT	20-10	λ / 4
MIRS-127-063- BOROFLOAT	12.7	6.35	BOROFLOAT	20-10	λ / 4
MIRS-254-063- BOROFLOAT	25.4	6.35	BOROFLOAT	20-10	λ / 4

Right Angle Folding Prisms, Uncoated

- 180° reflectors

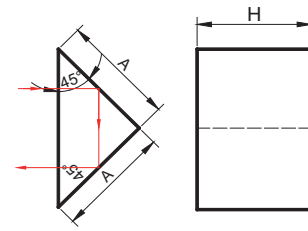

Order Information

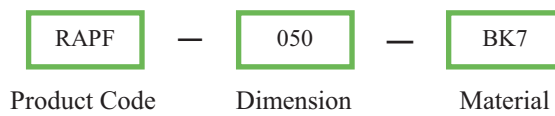

Right Angle Folding Prisms, Uncoated

Part Number	Dimension A=H (mm)	Material
RAPF-127-BK7	12.7	BK7
RAPF-254-BK7	25.4	BK7
RAPF-127-UVFS	12.7	UVFS
RAPF-254-UVFS	25.4	UVFS

- Our Right Angle Folding Prisms are also available with antireflection coating on hypotenuse in order to reduce surface loss.
- Coating specifications, please see page 2-3.
- Other sizes and coatings are available upon request.

Example : The legs may be coated with second-surface aluminum protected by black sealing paint to ensure grazing incidence reflection. These prisms are suitable for optical delay lines and for high power use.

Penta Prisms

Specifications

Material:	BK7
Dimension Tolerance:	± 0.1mm
Angular Tolerance:	± 3 arc min
Clear Aperture	>central 85% of dimension
Surface Quality:	40/20 scratch /dig
Flatness:	$\lambda/10$ at 632.8 nm
Chamfers:	<0.3mm face width x 45° ± 15°
Coating:	Reflecting surface aluminum coated with black paint overcoat Entrance and exit surfaces are uncoated

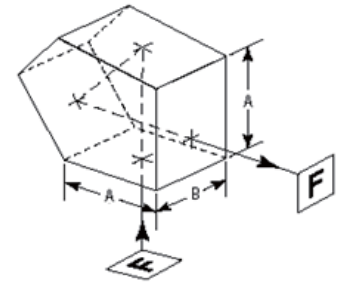

Order Information

PTP	—	100	—	100	—	BK7
Product Code		Size “A”=10.0 mm		Size “B” = 10.0 mm		Material

Penta Prisms

Part number	Size A (mm)	Size B (mm)
PTP-070-070-BK7	7.0mm	7.0mm
PTP-100-100-BK7	10.0mm	10.0mm
PTP-127-127-BK7	12.7mm	12.7mm
PTP-150-150-BK7	15.0mm	15.0mm
PTP-200-200-BK7	20.0mm	20.0mm
PTP-254-254-BK7	25.4mm	25.4mm

- Coatings: Optional, please see page 2,3 and 8.
- Better angular precision such as 1 min ,30sec ,15sec available upon request.
- Other sizes and material are available upon request.

Dove Prisms

Specifications

Material:	BK7 or UV fused silica
Dimension Tolerance:	±0.15 mm
Clear Aperture:	>central 85% of dimension
Angle Tolerance:	<3 arc min.
Surface Quality: :	40/20 scratch / dig
Surface Flatness:	$\lambda/4@632.8\text{nm}$
Chamfers:	<0.3mm face width x 45° ±15°

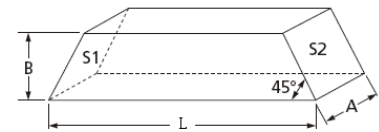

DPR: Dove Prisms used as rotator

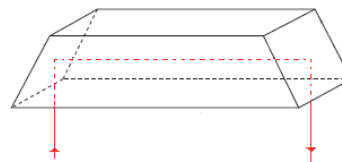

DPF: Dove Prisms, used as retroreflector

Order Information

DPR	—	100	—	100	—	BK7
Product Code		Size “A”=10mm		Size “B” =10mm		Material

Dove Prisms

Part Number	Size A (mm)	Size L (mm)	Size B (mm)	Material
DRR-100-100-BK7	10	42.3	10	BK7
DPR-150-150-BK7	15	63.5	15	BK7
DPR-200-200-BK7	20	84.7	20	BK7
DPR-100-100-UVFS	10	44.9	10	UVFS
DPR-150-150-UVFS	15	67.4	15	UVFS
DPR-200-200-UVFS	20	89.9	20	UVFS
DPF-127-635-BK7	12.7	18.0	6.35	BK7
DPF-254-127-BK7	25.4	35.9	12.7	BK7

- Our Dove Prisms are also available with antireflection coating on surfaces with light in and out, in order to reduce surface loss.
- Coatings: optional, please see page 2-3.
- Other sizes are available upon request.

Roof Prisms

Specifications

Material:	BK7
Dimension Tolerance:	±0.1 mm
Clear Aperture:	>central 85% of dimension
Angle Tolerance:	3 arc min.
Surface Quality:	< 40 / 20 scratch / dig
Surface Flatness:	< λ / 10 @ 633 nm
Chamfers:	<0.3mm face width x 45° ±15°

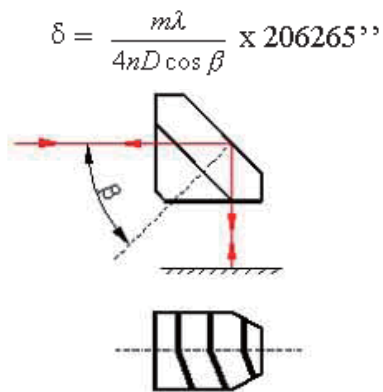
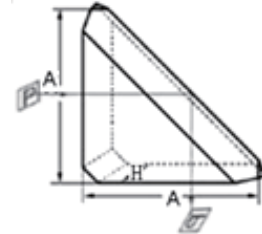

$$\delta = \frac{m\lambda}{4nD \cos \beta} \times 206265''$$

- δ: roof angle error
- D: clear aperture
- m: fringe down through the roof line
- β: angle between optical axis and vertical line of roof
- n: refractive index
- λ: wavelength

Order Information

RP —
 230 —
 315 —
 BK7
 Product Code Size "A"=23.0mm Size "H"=31.5mm Material

Roof Prisms

Part Number	A=(mm)	H (mm)	Material
RP-230-BK7	23.0	31.5	BK7

- Coatings: Optional, please see page 2-3.
- Other sizes , material and Roof angle error are available upon request.

Porro Prisms

Specifications

Material:	BK7 or UV fused Silica
Dimension Tolerance:	± 0.1 mm
Surface flatness:	$\lambda / 10 @ 633\text{nm}$
Surface Quality:	40/20 scratch / dig
Angular Deviation:	≤10 arc second
Knife Edge:	edge chips ≤5 μm
Clear Aperture:	>70% of central circular dimension
Chamfers:	<0.3mm face width x 45° ±15°



Order Information

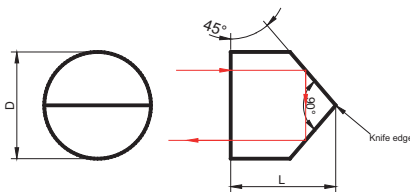

PRPC	—	127	—	053	—	BK7
Product Code		Size "D" =12.7mm		Size "L" =5.3mm		Material

Circular Porro Prisms

Part number	Size D (mm)	Size L (mm)	Material
PRPC-056-053-BK7	5.6	5.3	BK7
PRPC-127-127-BK7	12.7	12.7	BK7
PRPC-127-190-BK7	12.7	19.0	BK7
PRPC-254-381-BK7	25.4	38.1	BK7
PRPC-127-127-UVFS	12.7	12.7	UVFS
PRPC-127-190-UVFS	12.7	19.0	UVFS
PRPC-254-381-UVFS	25.4	38.1	UVFS

Order Information

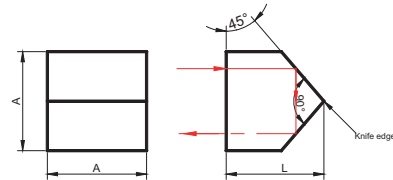

PRPS	—	056	—	053	—	BK7
Product Code		Size "A" =5.6mm		Size "L" =5.3mm		Material

Square Porro Prisms

Part number	Size A (mm)	Size L (mm)	Material
PRPS-056-053-BK7	5.6	5.3	BK7
PRPS-127-127-BK7	12.7	12.7	BK7
PRPS-127-190-BK7	12.7	19.0	BK7
PRPS-254-381-BK7	25.4	38.1	BK7
PRPS-127-127-UVFS	12.7	12.7	UVFS
PRPS-127-190-UVFS	12.7	19.0	UVFS
PRPS-254-381-UVFS	25.4	38.1	UVFS

- Coatings: optional, please see page 2-3.
- Other sizes and material are available upon request.

Retro-Reflectors

Specifications

Material:	BK7
Dimension Tolerance:	±0.1 mm
Clear Aperture:	>85% of central circular dimension
Angle Tolerance:	≤3 arc min
Surface Quality :	20/10 scratch / dig
Wavefront Distortion:	λ/8@633nm

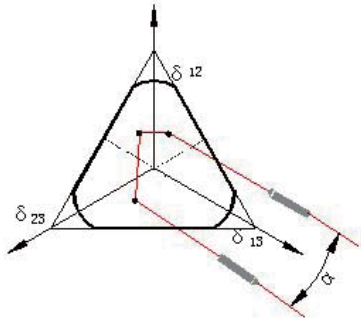
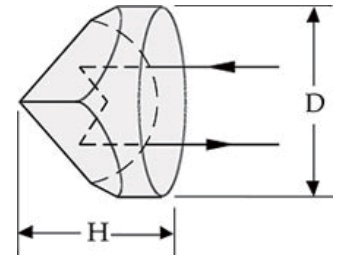

$$\alpha = 4.95 \quad (\delta_{12}, \delta_{23}, \delta_{13})$$

α : Beam deviation
 δ : Angle error of three mutually perpendicular surfaces

Order Information:

RRP	—	127	—	095	—	BK7
Product Code		Dia =12.7mm		Height (H)=9.5mm		Material

Retro-Reflectors

Part number	Diameter D(mm)	Height H(mm)
RRP-127-095-BK7	12.7	9.5
RRP-254-188-BK7	25.4	18.8
RRP-380-285-BK7	38.0	28.5
RRP-640-480-BK7	64.0	48.0

• Other sizes and material are available upon requests.

Anamorphic Prisms

Specifications

Material:	N-SF11
Dimension Tolerance:	$\pm 0.1\text{mm}$
Angular Tolerance:	<10 arc min
Clear Aperture:	>80% of the central area
Surface Quality:	40/20 scratch/dig
Flatness:	$\lambda/8@632.8\text{nm}$
Coating:	single layer MgF_2

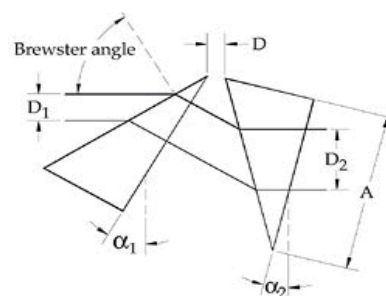

Order Information

ANP	—	X020	—	050	—	NSF11
Product Code		Magnify: “D2 / D1”=2		Clear Aperture		Material

Anamorphic Prisms

Part Number	X	CA	Material
ANP-X020-050-NSF11	2	5.0	N-SF11
ANP-X025-150-NSF11	2.5	15.0	N-SF11

- Coatings: optional, please see page 2-3.
- Other sizes and magnify are available upon request.

Pellin Broca Prisms

Specifications

Material:	BK7 or UV fused silica
Dimension Tolerance:	± 0.2mm
Angular Tolerance:	± 3 arc min
Clear aperture:	>80% of the central Area
Surface quality:	10/5 scratch /dig
Flatness:	$\lambda/10@632.8\text{nm}$

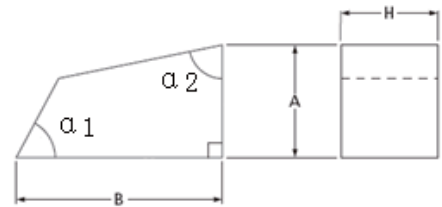
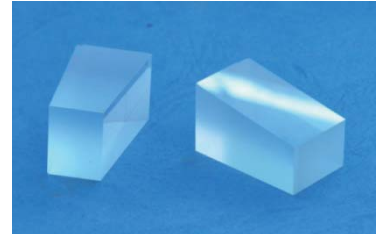

Order Information

PBP	—	235	—	400	—	127	—	600	—	795	—	BK7
Product Code		Size "A"		Size "B"		Size "H"		Angle "α1"		Angle "α2"		Material
		=23.5mm		=23.5mm		=23.5mm		= 60°		= 79.5°		

Pellin Broca Prisms

Part number	A	B	H	α1	α2	Material
PBP-235-400-127-600-795-BK7	23.5	40	12.7	60°	79.5°	BK7
PBP-110-200-640-600-795-UVFS	11	20	6.4	60°	79.5°	UVFS
PBP-235-400-127-600-795-UVFS	23.5	40	12.7	60°	79.5°	UVFS

- Coatings: optional, please see page 2-3.
- Other sizes are available upon request.

Equilateral Dispersive Prisms

Specifications

Material:	N-SF10 or BK7
Dimension Tolerance:	± 0.1 mm
Clear Aperture:	>85% of central dimension
Angular Deviation:	≤ 3 arc min
Surface Quality:	20/10 scratch/dig
Surface Flatness:	$\lambda/8@632.8\text{nm}$
Chamfers:	<0.3mm face width x $45^\circ \pm 15^\circ$

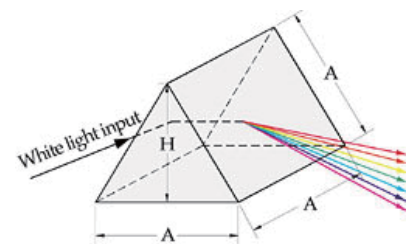

Order Information

EQP	—	150	—	BK7
Product Code		Size "A"		Material
		=15.0mm		

Equilateral Dispersive Prisms

Part number	A (mm)	H (mm)	Material
EQP-150-BK7	15.0	12.99	BK7
EQP-200-BK7	20.0	17.32	BK7
EQP-250-BK7	25.0	21.65	BK7
EQP-300-BK7	30.0	25.98	BK7
EQP-350-BK7	35.0	30.30	BK7
EQP-400-BK7	40.0	34.64	BK7
EQP-500-BK7	50.0	43.30	BK7
EQP-600-BK7	60.0	51.96	BK7
EQP-300-NSF10	30.0	25.98	N-SF10
EQP-600-NSF10	60.0	51.96	N-SF10

- Coatings: optional, please see page 2-3.
- Other sizes and material are available upon request.

Plano-Convex Lenses

Specifications

Material:	BK7 or UV fused silica
Focal Length Tolerance:	$\pm 1\%$ @589nm
Design Wavelength:	589nm
Centration:	≤ 3 arc min
Diameter Tolerance:	+0/-0.1
Clear Aperture :	\geq central 90% of diameter
Center Thickness Tolerance:	± 0.1 mm
Edge Thickness:	3.0 mm , nominal
Surface Quality:	20-10 (UVFS) / 40-20(BK7)
Surface Accuracy:	$\leq 1.5\lambda$ power, $\lambda/2$ irregularity (UVFS) $\leq 1.5\lambda$ power, $\lambda/4$ irregularity (BK7)
Chamfers:	0-0.8mm face width $\times 45^\circ \pm 15^\circ$ typical

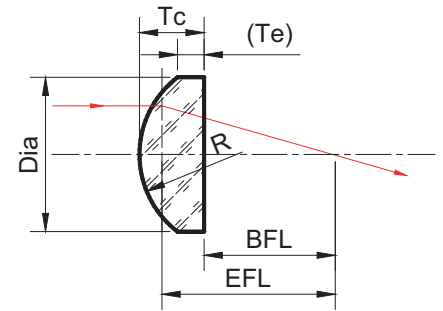

- Other diameter, focus length ,and material are available upon request.

Order Information

LPX	—	063	—	R065	—	BK7
Product Code		Dia=6.3mm		Radius =6.563mm		Material

Plano-Convex Lenses

Part Number	Dia (mm)	EFL (mm)	R (mm)	Tc (mm)	Te (mm)	Material
LPX-063-R065-BK7	6.35	12.7	6.563	3.819	3.0	BK7
LPX-063-R131-BK7	6.35	25.4	13.127	3.390	3.0	BK7
LPX-063-R164-BK7	6.35	31.8	16.495	3.308	3.0	BK7
LPX-063-R196-BK7	6.35	38.1	19.690	3.258	3.0	BK7
LPX-127-R131-BK7	12.7	25.4	13.127	5.330	3.0	BK7
LPX-127-R196-BK7	12.7	38.1	19.690	4.052	3.0	BK7
LPX-127-R259-BK7	12.7	50.2	25.943	3.789	3.0	BK7
LPX-127-R390-BK7	12.7	75.6	39.070	3.519	3.0	BK7
LPX-127-R516-BK7	12.7	100	51.680	3.392	3.0	BK7
LPX-127-R775-BK7	12.7	150	77.520	3.251	3.0	BK7
LPX-127-R1292-BK7	12.7	250	129.200	3.156	3.0	BK7

Plano-Convex Lenses

Part Number	Dia (mm)	EFL (mm)	R (mm)	Tc (mm)	Te(mm)	Material
LPX-254-R131-BK7	25.4	25.4	13.127	12.807	3.0	BK7
LPX-254-R259-BK7	25.4	50.2	25.943	6.321	3.0	BK7
LPX-254-R390-BK7	25.4	75.6	39.070	5.122	3.0	BK7
LPX-254-R516-BK7	25.4	100	51.68	4.585	3.0	BK7
LPX-254-R775-BK7	25.4	150	77.52	4.047	3.0	BK7
LPX-254-R1033-BK7	25.4	200	103.36	3.783	3.0	BK7
LPX-254-R1292-BK7	25.4	250	129.20	3.626	3.0	BK7
LPX-254-R1550-BK7	25.4	300	155.04	3.521	3.0	BK7
LPX-254-R2067-BK7	25.4	400	206.72	3.390	3.0	BK7
LPX-254-R2584-BK7	25.4	500	258.4	3.312	3.0	BK7
LPX-254-R3876-BK7	25.4	750	387.6	3.208	3.0	BK7
LPX-254-R5168-BK7	25.4	1000	516.8	3.156	3.0	BK7
LPX-508-R516-BK7	50.8	100	51.68	9.673	3.0	BK7
LPX-508-R775-BK7	50.8	150	77.52	7.279	3.0	BK7
LPX-508-R1033-BK7	50.8	200	103.36	6.17	3.0	BK7
LPX-508-R1292-BK7	50.8	250	129.2	5.521	3.0	BK7
LPX-508-R1550-BK7	50.8	300	155.04	5.059	3.0	BK7
LPX-508-R2067-BK7	50.8	400	206.72	4.566	3.0	BK7
LPX-508-R2584-BK7	50.8	500	258.4	4.251	3.0	BK7
LPX-508-R3876-BK7	50.8	750	387.6	3.833	3.0	BK7
LPX-508-R5168-BK7	50.8	1000	516.8	3.625	3.0	BK7

LPX-063-R058-UVFS	6.35	12.7	5.829	3.941	3.0	UVFS
LPX-127-R116-UVFS	12.7	25.4	11.659	4.881	3.0	UVFS
LPX-127-R174-UVFS	12.7	38.1	17.465	4.200	3.0	UVFS
LPX-127-R230-UVFS	12.7	50.2	23.012	3.89	3.0	UVFS
LPX-127-R346-UVFS	12.7	75.6	34.656	3.59	3.0	UVFS
LPX-254-R174-UVFS	25.4	38.1	17.465	8.48	3.0	UVFS
LPX-254-R230-UVFS	25.4	50.2	23.042	6.816	3.0	UVFS
LPX-254-R347-UVFS	25.4	75.6	34.7	5.408	3.0	UVFS
LPX-254-R459-UVFS	25.4	100	45.9	4.792	3.0	UVFS

Plano-Convex Lenses

Part Number	Dia (mm)	EFL(mm)	R (mm)	Tc (mm)	Material
LPX-254-R688-UVFS	25.4	150	68.85	4.181	UVFS
LPX-254-R918-UVFS	25.4	200	91.8	3.883	UVFS
LPX-254-R1146-UVFS	25.4	250	114.603	3.71	UVFS
LPX-254-R1604-UVFS	25.4	350	160.445	3.5	UVFS
LPX-254-R2295-UVFS	25.4	500	229.5	3.352	UVFS
LPX-254-R3438-UVFS	25.4	750	343.81	3.23	UVFS
LPX-254-R4590-UVFS	25.4	1000	459.00	3.176	UVFS
LPX-508-R459-UVFS	50.8	100	45.9	10.668	UVFS
LPX-508-R918-UVFS	50.8	200	91.8	6.584	UVFS
LPX-508-R1377-UVFS	50.8	300	137.7	5.363	UVFS
LPX-508-R2295-UVFS	50.8	500	229.5	4.41	UVFS

Antireflective coating

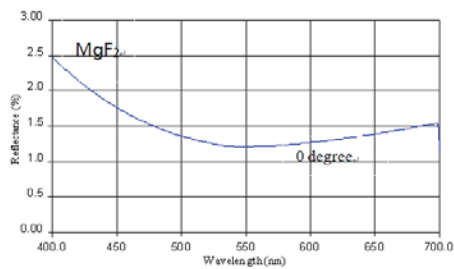
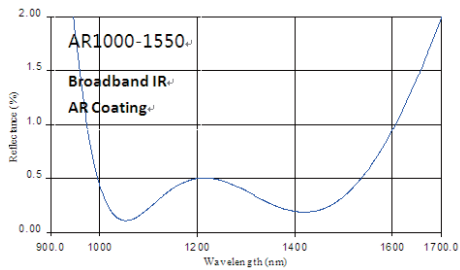
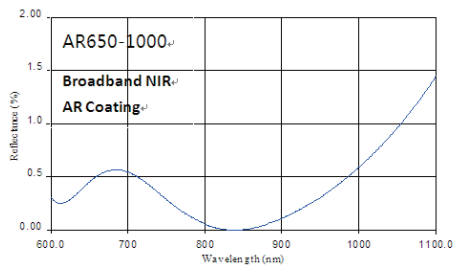
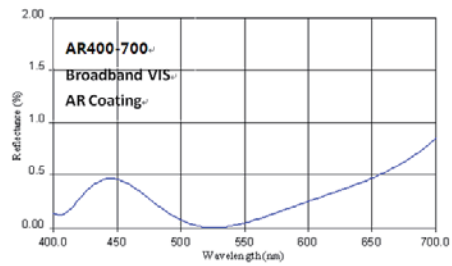
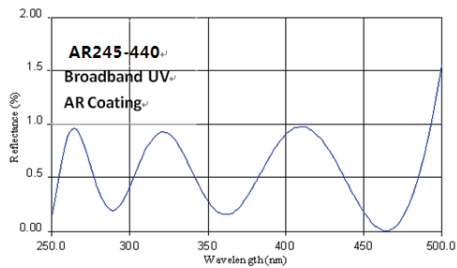

Plano-Concave Lenses

Specifications

Material:	BK7 or UV fused silica
Focal Length Tolerance:	$\pm 1\% @ 589\text{nm}$
Design Wavelength:	589nm
Centration:	≤ 3 arc min
Diameter Tolerance:	+0/-0.1
Clear Aperture	\geq central 90% of diameter
Center Thickness and Tolerance	2.5 ± 0.1 mm
Edge Thickness:	Nominal Value
Surface Quality:	20-10 (UVFS) / 40-20 (BK7)
Surface Accuracy:	$\leq 1.5\lambda$ power, $\lambda/2$ irregularity (UVFS) $\leq 1.5\lambda$ power, $\lambda/4$ irregularity (BK7)
Chamfers:	0-0.8mm face width $\times 45^\circ \pm 15^\circ$ typical

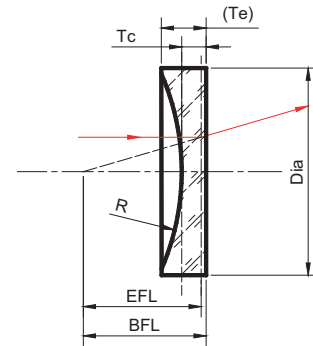

Order Information

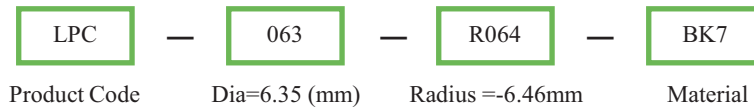

Plano-Concave Lenses

Part Number	Dia (mm)	EFL (mm)	R (mm)	Te (mm)	Tc (mm)	Material
LPC-063-R064-BK7	6.35	-12.5	-6.46	3.17	2.5	BK7
LPC-063-R129-BK7	6.35	-25	-12.92	2.82	2.5	BK7
LPC-127-R129-BK7	12.7	-25	-12.92	3.83	2.5	BK7
LPC-127-R258-BK7	12.7	-50	-25.84	3.14	2.5	BK7
LPC-127-R387-BK7	12.7	-75	-38.76	2.92	2.5	BK7
LPC-127-R516-BK7	12.7	-100	-51.68	2.82	2.5	BK7
LPC-254-R129-BK7	25.4	-25	-12.92	9.4	2.5	BK7
LPC-254-R258-BK7	25.4	-50	-25.84	5.17	2.5	BK7
LPC-254-R387-BK7	25.4	-75	-38.76	4.22	2.5	BK7
LPC-254-R516-BK7	25.4	-100	-51.68	3.78	2.5	BK7
LPC-254-R775-BK7	25.4	-150	-77.52	3.35	2.5	BK7
LPC-254-R1033-BK7	25.4	-200	-103.36	3.13	2.5	BK7
LPC-508-R387-BK7	50.8	-75	-38.76	9.96	2.5	BK7
LPC-508-R516-BK7	50.8	-100	-51.68	7.83	2.5	BK7
LPC-508-R775-BK7	50.8	-150	-77.52	5.95	2.5	BK7

Plano-Concave Lenses

Part Number	Dia (mm)	EFL (mm)	R (mm)	Te (mm)	Tc(mm)	Material
LPC-508-R1036-BK7	50.8	-200	-103.36	5.06	2.5	BK7
LPC-508-R1292-BK7	50.8	-250	-129.2	4.54	2.5	BK7
LPC-508-R2584-BK7	50.8	-500	-258.4	3.51	2.5	BK7

LPC-063-R057-UVFS	6.35	-12.5	-5.737	3.26	2.5	UVFS
LPC-063-R114-UVFS	12.7	-25	-11.475	4.02	2.5	UVFS
LPC-254-R229-UVFS	25.4	-50	-22.95	5.55	2.5	UVFS
LPC-254-R344-UVFS	25.4	-75	-34.425	4.45	2.5	UVFS
LPC-254-R459-UVFS	25.4	-100	-45.9	3.95	2.5	UVFS
LPC-254-R688-UVFS	25.4	-150	-68.85	3.46	2.5	UVFS
LPC-254-R918-UVFS	25.4	-200	-91.8	3.21	2.5	UVFS
LPC-254-R1147-UVFS	25.4	-250	-114.75	3.07	2.5	UVFS
LPC-254-R4590-UVFS	25.4	-1000	-459.000	2.64	2.5	UVFS
LPC-508-R459-UVFS	50.8	-100	-45.9	8.60	2.5	UVFS
LPC-508-R688-UVFS	50.8	-150	-68.85	6.41	2.5	UVFS
LPC-508-R918-UVFS	50.8	-200	-91.8	5.39	2.5	UVFS
LPC-508-R1147-UVFS	50.8	-250	-114.75	4.80	2.5	UVFS
LPC-508-R2295-UVFS	50.8	-500	-229.5	3.64	2.5	UVFS
LPC-508-R4590-UVFS	50.8	-1000	-459.00	3.07	2.5	UVFS

- Please note : Other sizes and focal length are available upon request. Also the lens ring mounts are available upon request.

Bi-Convex Lenses

Specifications

Material:	BK7 or UV fused silica
Focal Length Tolerance:	$\pm 1\% @ 589\text{nm}$
Design Wavelength:	589nm
Centration:	≤ 3 arc min
Diameter Tolerance:	+0/-0.1
Clear Aperture	\geq central 90% of diameter
Center Thickness Tolerance	± 0.1 mm
Edge Thickness:	3.0 mm , nominal
Surface Quality:	20-10 (UVFS) / 40-20(BK7)
Surface Accuracy:	$\leq 1.5\lambda$ power, $\lambda/2$ irregularity (UVFS) $\leq 1.5\lambda$ power, $\lambda/4$ irregularity (BK7)
Chamfers:	0-0.8mm face width $\times 45^\circ \pm 15^\circ$ typical

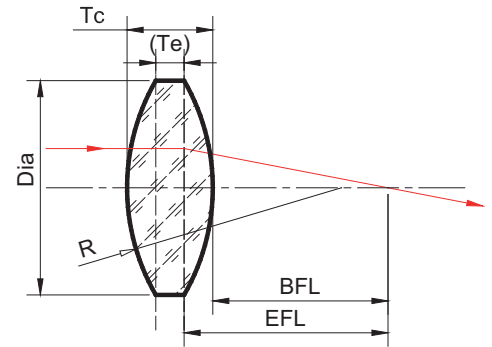

Order Information

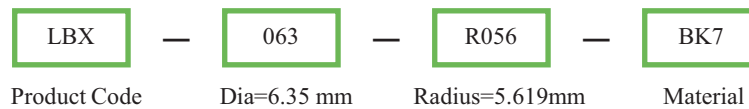

Bi-Convex Lenses

Part Number	Dia (mm)	EFL (mm)	R (mm)	Tc (mm)	Te(mm)	Material
LBX-063-R056-BK7	6.35	6.4	5.619	4.96	3.0	BK7
LBX-063-R124-BK7	6.35	12.7	12.44	3.82	3.0	BK7
LBX-063-R190-BK7	6.35	19	19.017	3.53	3.0	BK7
LBX-063-R256-BK7	6.35	25.4	25.663	3.39	3.0	BK7
LBX-127-R118-BK7	12.7	12.7	11.868	6.68	3.0	BK7
LBX-127-R187-BK7	12.7	19	18.705	5.22	3.0	BK7
LBX-127-R254-BK7	12.7	25.4	25.444	4.61	3.0	BK7
LBX-127-R386-BK7	12.7	38.1	38.679	4.05	3.0	BK7
LBX-127-R512-BK7	12.7	50.2	51.234	3.79	3.0	BK7
LBX-127-R643-BK7	12.7	62.9	64.392	3.628	3.0	BK7
LBX-127-R775-BK7	12.7	75.6	77.538	3.521	3.0	BK7
LBX-254-R166-BK7	25.4	19	16.687	14.725	3.0	BK7
LBX-254-R243-BK7	25.4	25.4	24.397	10.132	3.0	BK7
LBX-254-R380-BK7	25.4	38.1	38.085	7.36	3.0	BK7
LBX-254-R508-BK7	25.4	50.2	50.806	6.226	3.0	BK7

Bi-Convex Lenses

Part Number	Dia (mm)	EFL (mm)	R (mm)	Tc (mm)	Te(mm)	Material
LBX-254-R640-BK7	25.4	62.9	64.057	5.543	3.0	BK7
LBX-254-R772-BK7	25.4	75.6	77.265	5.102	3.0	BK7
LBX-254-R904-BK7	25.4	88.3	90.446	4.792	3.0	BK7
LBX-254-R1025-BK7	25.4	100	102.577	4.578	3.0	BK7
LBX-254-R1284-BK7	25.4	125	128.476	4.258	3.0	BK7
LBX-254-R1543-BK7	25.4	150	154.353	4.047	3.0	BK7
LBX-254-R1802-BK7	25.4	175	180.219	3.896	3.0	BK7
LBX-254-R2060-BK7	25.4	200	206.078	3.783	3.0	BK7
LBX-254-R2577-BK7	25.4	250	257.789	3.626	3.0	BK7
LBX-254-R5162-BK7	25.4	500	516.245	3.313	3.0	BK7
LBX-254-R10330-BK7	25.4	1000	1033.074	3.156	3.0	BK7
LBX-508-R1017-BK7	50.8	100	101.729	9.444	3.0	BK7
LBX-508-R2576-BK7	50.8	250	257.646	5.512	3.0	BK7
LBX-508-R5160-BK7	50.8	500	516.098	4.251	3.0	BK7

LBX-063-R110-UVFS	6.35	12.7	11.003	3.936	3.0	UVFS
LBX-127-R103-UVFS	12.7	12.7	10.358	7.349	3.0	UVFS
LBX-127-R225-UVFS	12.7	25.4	22.532	4.826	3.0	UVFS
LBX-254-R153-UVFS	25.4	20	15.388	16	3.0	UVFS
LBX-254-R213-UVFS	25.4	25.4	21.366	11.368	3.0	UVFS
LBX-254-R281-UVFS	25.4	32	28.11	7.5	3.0	UVFS
LBX-254-R450-UVFS	25.4	50.2	45.013	6.657	3.0	UVFS
LBX-254-R685-UVFS	25.4	75.6	68.547	5.373	3.0	UVFS
LBX-254-R910-UVFS	25.4	100	91.045	4.78	3.0	UVFS
LBX-254-R1370-UVFS	25.4	150	137.045	4.179	3.0	UVFS
LBX-254-R1829-UVFS	25.4	200	182.992	3.882	3.0	UVFS
LBX-254-R2289-UVFS	25.4	250	228.925	3.705	3.0	UVFS
LBX-254-R4584-UVFS	25.4	500	458.46	3.350	3.0	UVFS
LBX-254-R9174-UVFS	25.4	1000	917.498	3.176	3.0	UVFS
LBX-508-R1825-UVFS	50.8	200	182.571	6.551	3.0	UVFS
LBX-508-R4583-UVFS	50.8	500	458.325	4.409	3.0	UVFS

- Please note : Other sizes and focal length are available upon request. Also the lens ring mounts are available upon request.

Bi-Concave Lenses

Specifications

Material:	BK7 or UV fused silica
Focal Length Tolerance:	$\pm 1\% @ 589\text{nm}$
Design Wavelength:	589nm
Centration:	≤ 3 arc min
Diameter Tolerance:	+0/-0.1
Clear Aperture	\geq central 90% of diameter
Center Thickness Tolerance	± 0.1 mm
Center Thickness:	2.5 mm , nominal
Surface Quality:	20-10 (UVFS) / 40-20(BK7)
Surface Accuracy:	$\leq 1.5\lambda$ power, $\lambda/2$ irregularity (UVFS) $\leq 1.5\lambda$ power, $\lambda/4$ irregularity (BK7)
Chamfers:	0-0.8mm face width $\times 45^\circ \pm 15^\circ$ typical

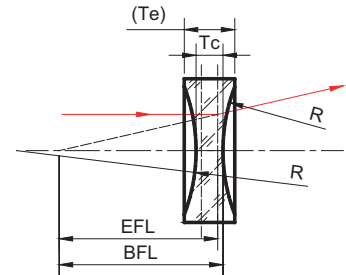

Order Information

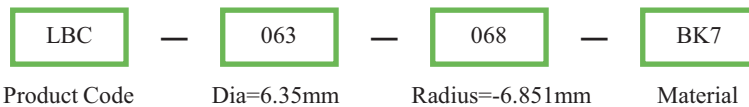

Bi-Concave Lenses

Part Number	Dia (mm)	EFL (mm)	R (mm)	Te (mm)	Tc(mm)	Material
LBC-063-R068-BK7	6.35	-6.3	-6.851	3.75	2.5	BK7
LBC-063-R133-BK7	6.35	-12.5	-13.333	3.12	2.5	BK7
LBC-127-R133-BK7	12.7	-12.5	-13.333	5.07	2.5	BK7
LBC-127-R262-BK7	12.7	-25	-26.259	3.76	2.5	BK7
LBC-127-R521-BK7	12.7	-50	-52.103	3.13	2.5	BK7
LBC-127-R779-BK7	12.7	-75	-77.943	2.92	2.5	BK7
LBC-127-R1037-BK7	12.7	-100	-103.785	2.82	2.5	BK7
LBC-254-R262-BK7	25.4	-25	-26.259	7.74	2.5	BK7
LBC-254-R521-BK7	25.4	-50	-52.103	5.04	2.5	BK7
LBC-254-R779-BK7	25.4	-75	-77.943	4.19	2.5	BK7
LBC-254-R1037-BK7	25.4	-100	-103.785	3.76	2.5	BK7
LBC-254-R1554-BK7	25.4	-150	-155.466	3.34	2.5	BK7
LBC-254-R2071-BK7	25.4	-200	-207.148	3.13	2.5	BK7
LBC-508-R779-BK7	50.8	-75	-77.943	9.36	2.5	BK7
LBC-508-R1037-BK7	50.8	-100	-103.785	7.60	2.5	BK7
LBC-508-R1554-BK7	50.8	-150	-155.466	5.88	2.5	BK7

Bi-Concave Lenses

Part Number	Dia (mm)	EFL (mm)	R (mm)	Te (mm)	Tc(mm)	Material
LBC-508-R2071-BK7	50.8	-200	-207.148	5.03	2.5	BK7
LBC-508-R2588-BK7	50.8	-250	-258.824	4.52	2.5	BK7
LBC-508-R5172-BK7	50.8	-500	517.255	3.51	2.5	BK7

LBC-063-R118-UVFS	6.35	-12.5	-11.865	3.20	2.5	UVFS
LBC-127-R232-UVFS	12.7	-25	-23.237	3.92	2.5	UVFS
LBC-254-R462-UVFS	25.4	-50	-46.29	5.37	2.5	UVFS
LBC-254-R692-UVFS	25.4	-75	-69.241	4.40	2.5	UVFS
LBC-254-R921-UVFS	25.4	-100	-92.192	3.92	2.5	UVFS
LBC-254-R1380-UVFS	25.4	-150	-138.092	3.45	2.5	UVFS
LBC-254-R1839-UVFS	25.4	-200	-183.993	3.21	2.5	UVFS
LBC-254-R2298-UVFS	25.4	-250	-229.890	3.07	2.5	UVFS
LBC-254-R9183-UVFS	25.4	-1000	-918.377	2.64	2.5	UVFS
LBC-508-R921-UVFS	50.8	-100	-92.192	8.26	2.5	UVFS
LBC-508-R1380-UVFS	50.8	-150	-138.092	6.31	2.5	UVFS
LBC-508-R1839-UVFS	50.8	-200	-183.993	5.35	2.5	UVFS
LBC-508-R2298-UVFS	50.8	-250	-229.890	4.78	2.5	UVFS
LBC-508-R4593-UVFS	50.8	-500	-459.380	3.64	2.5	UVFS
LBC-508-R9183-UVFS	50.8	-1000	-918.377	3.07	2.5	UVFS

- Please note : Other sizes and focal length are available upon request. Also the lens ring mounts are available upon request.

Meniscus Lenses

Specifications

Material:	BK7 or UV fused silica
Focal Length Tolerance:	$\pm 1\% @ 589\text{nm}$
Design Wavelength:	589nm
Centration:	≤ 3 arc min
Diameter Tolerance:	+0/-0.1
Clear Aperture	\geq central 90% of diameter
Center Thickness Tolerance	± 0.1 mm
Edge Thickness:	3.5 mm , nominal
Surface Quality:	20-10 (UVFS) / 40-20(BK7)
Surface Accuracy:	$\leq 1.5\lambda$ power, $\lambda/2$ irregularity (UVFS) $\leq 1.5\lambda$ power, $\lambda/4$ irregularity (BK7)
Chamfers:	0-0.8mm face width $\times 45^\circ \pm 15^\circ$ typical

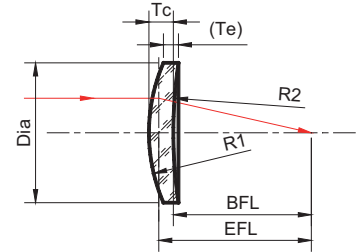

Order Information

LMS	—	254	—	R515	—	R1000	—	BK7
Product Code		Diameter 25.4mm		R1=51.56mm		R2 =-100mm		Material

Meniscus Lenses

Part Number	Dia (mm)	Tc(mm)	Te (mm)	R1(mm)	R2(mm)	EFL (mm)	Material
LMS-254-R515-R1000-BK7	25.4	4.28	3.5	51.56	-100	200	BK7
LMS-254-R857-R2500-BK7	25.4	4.12	3.5	85.7	-250	250	BK7
LMS-254-R1025-R3000-BK7	25.4	4.02	3.5	102.58	-300	300	BK7
LMS-254-R1266-R3220-BK7	25.4	3.89	3.5	126.66	-322	400	BK7
LMS-254-R1554-R3876-BK7	25.4	3.81	3.5	155.466	-387.6	500	BK7

- Please note : Other sizes and focal length are available upon request. Also the lens ring mounts are available upon required.

Negative Meniscus Lenses

Specifications

Material:	BK7 or UV fused silica
Focal Length Tolerance:	± 1%@589nm
Design Wavelength:	589nm
Centration:	≤3 arc min
Diameter Tolerance:	+0/-0.1
Clear Aperture	≥ central 90% of diameter
Center Thickness Tolerance	± 0.1 mm
Surface Quality:	20-10 (UVFS) / 40-20(BK7)
Surface Accuracy:	≤1.5λ power, λ /2 irregularity (UVFS) ≤1.5λ power, λ /4 irregularity (BK7)
Chamfers:	0-0.8mm face width × 45° ± 15° typical

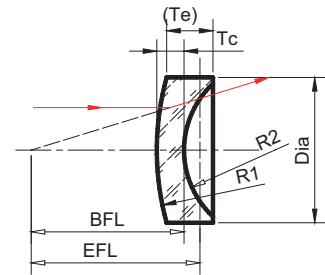

Order Information

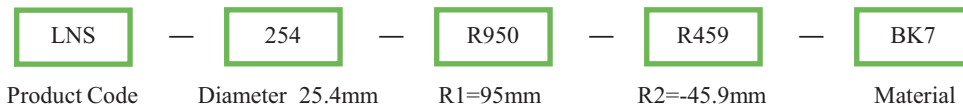

BK7 Meniscus Lenses

Part Number	Dia (mm)	Tc(mm)	Te (mm)	R1(mm)	R2(mm)	EFL (mm)	Material
LNS-254-R950-R459-BK7	25.4	2.86	3.8	95.0	-45.9	-175.0	BK7
LNS-254-R1000-R431-BK7	25.4	3.73	4.77	100	-43.11	-150.0	BK7
LNS-254-R900-R373-BK7	25.4	2.02	3.3	100	-38.973	-125.0	BK7
LNS-254-R900-R326-BK7	25.4	2.32	3.92	100	-33.8	-100	BK7

- Please note : Other sizes and focal length are available upon request. Also the lens ring mounts are available upon request.

Plano-Convex Cylindrical Lenses

Specifications

Material:	BK7 or UV fused silica
Focal Length Tolerance:	$\pm 2\%$ @589nm
Centration:	≤ 3 arc min
Diameter Tolerance:	+0/-0.1
Clear Aperture :	\geq central 90% of diameter
Center Thickness Tolerance:	± 0.1 mm
Edge Thickness	3.0mm,Nominal Value
Surface Quality:	40/20 scratch/dig
Surface Accuracy: (over the clear aperture)	$\leq \lambda/2$ irregularity in Y axis at 632.8 nm $\leq \lambda/4$ /cm irregularity in X axis at 632.8 nm
Chamfers:	0-0.8mm face width $\times 45^\circ \pm 15^\circ$ typical

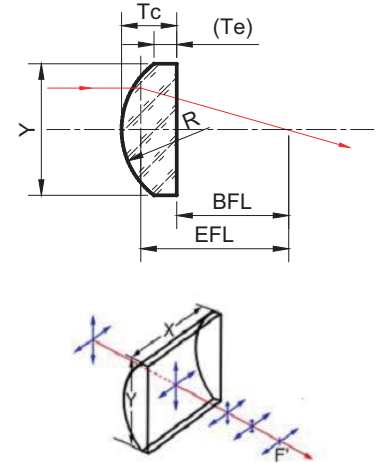

Order Information

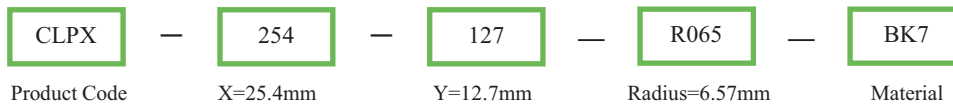

Plano-Convex Cylindrical Lenses

Part Number	X (mm)	Y (mm)	EFL (mm)	R (mm)	Tc (mm)	Te (mm)	Material
CLPX-254-127-R065-BK7	25.4	12.7	12.7	6.57	7.9	3.0	BK7
CLPX-508-254-R197-BK7	50.8	25.4	38.1	19.7	7.64	3.0	BK7
CLPX-508-254-R259-BK7	50.8	25.4	50.2	25.95	6.32	3.0	BK7
CLPX-508-254-R325-BK7	50.8	25.4	62.9	32.52	5.58	3.0	BK7
CLPX-508-254-R390-BK7	50.8	25.4	75.6	39.09	5.12	3.0	BK7
CLPX-508-508-R517-BK7	50.8	50.8	100	51.7	9.67	3.0	BK7
CLPX-508-508-R775-BK7	50.8	50.8	150	77.55	7.28	3.0	BK7
CLPX-508-508-R1034-BK7	50.8	50.8	200	103.4	6.17	3.0	BK7
CLPX-508-508-R1551-BK7	50.8	50.8	300	155.1	5.09	3.0	BK7
CLPX-508-254-R239-UVFS	50.8	25.4	50.2	23.09	6.81	3.0	UVFS
CLPX-508-254-R460-UVFS	50.8	25.4	100	46.00	4.79	3.0	UVFS
CLPX-508-508-R690-UVFS	50.8	50.8	150	69.00	7.85	3.0	UVFS
CLPX-508-508-R920-UVFS	50.8	50.8	200	92.00	6.58	3.0	UVFS
CLPX-508-508-R1380-UVFS	50.8	50.8	300	138.00	5.36	3.0	UVFS

● Please note : Other sizes and focal are available upon request. Also the lens ring mounts are available upon request.

Plano-Concave Cylindrical Lenses

Specifications

Material:	BK 7 or UV fused silica
Focal Length Tolerance:	$\pm 2\%$ @589nm
Centration:	≤ 3 arc min
Diameter Tolerance:	+0/-0.1
Clear Aperture :	\geq central 90% of diameter
Center Thickness and Tolerance:	2.5 \pm 0.1 mm
Edge Thickness	Nominal Value
Surface Quality:	40/20 scratch/dig
Surface Accuracy: (over the clear aperture)	$\leq \lambda/2$ irregularity in Y axis at 632.8 nm $\leq \lambda/4$ /cm irregularity in X axis at 632.8 nm
Chamfers:	0-0.8mm face width $\times 45^\circ \pm 15^\circ$ typical

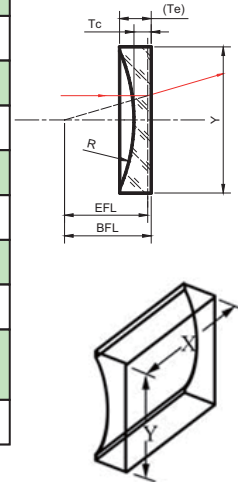

Order Information

CLPC	—	254	—	063	—	R033	—	BK7
Product Code		X =25.4mm		Y=6.35mm		R =-3.31mm		Material

Plano-Concave Cylindrical Lenses

Part Number	X (mm)	Y (mm)	EFL (mm)	R (mm)	Tc (mm)	Te (mm)	Material
CLPC-254-063-R033-BK7	25.4	6.35	-6.4	-3.31	6.0	7.36	BK7
CLPC-254-127-R065-BK7	25.4	12.7	-12.7	-6.57	6.0	9.58	BK7
CLPC-254-127-R129-BK7	25.4	12.7	-25	-12.92	6.0	7.4	BK7
CLPC-508-190-R258-BK7	50.8	19.0	-50	-25.85	6.0	7.62	BK7
CLPC-508-254-R750-BK7	50.8	25.4	-75	-38.77	6.0	7.97	BK7
CLPC-508-254-R517-BK7	50.8	25.4	-100	-51.7	6.0	7.46	BK7
CLPC-508-254-R775-BK7	50.8	25.4	-150	-77.55	6.0	6.97	BK7
CLPC-508-254-R1034-BK7	50.8	25.4	-200	-103.4	6.0	6.72	BK7
CLPC-508-190-R116-UVFS	50.8	19.0	-25.4	-11.68	2.5	6.73	UVFS
CLPC-508-254-R230-UVFS	50.8	25.4	-50.2	-23.09	2.5	5.99	UVFS
CLPC-508-254-R460-UVFS	50.8	25.4	-100	-46.0	2.5	4.15	UVFS
CLPC-508-508-R690-UVFS	50.8	50.8	-150	-69.0	2.5	7.15	UVFS
CLPC-508-508-R920-UVFS	50.8	50.8	-200	-92.0	2.5	5.93	UVFS
CLPC-508-508-R1380-UVFS	50.8	50.8	-300	-138.0	2.5	4.76	UVFS

- Please note : Other sizes and focal length are available upon request. Also the lens ring mounts are available upon request.

Waveplates

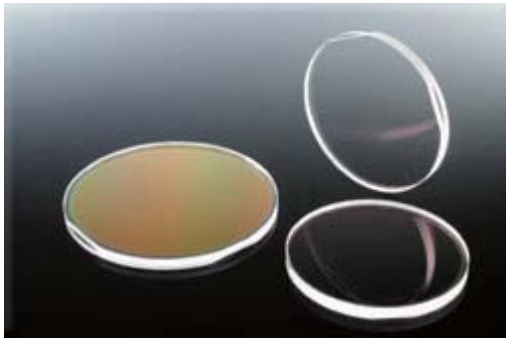

Principle of Waveplate

Waveplates (retardation plates or phase shifters) are made from material which exhibit birefringence. The velocities of the extraordinary and ordinary rays through the birefringent material vary inversely with their refractive indices. The difference in velocities gives rise to a phase difference when the two beams recombine. In the case of an incident linearly polarized beam this is given by

$$\delta = \frac{2 \cdot \pi \cdot (n_e - n_o) \cdot d}{\lambda}$$

where:

δ -phase difference;

d -thickness;

n_e, n_o -refractive index of extraordinary and ordinary rays;

λ -wavelength.

At any specific wavelength, the phase difference is given by the thickness of the retarder.

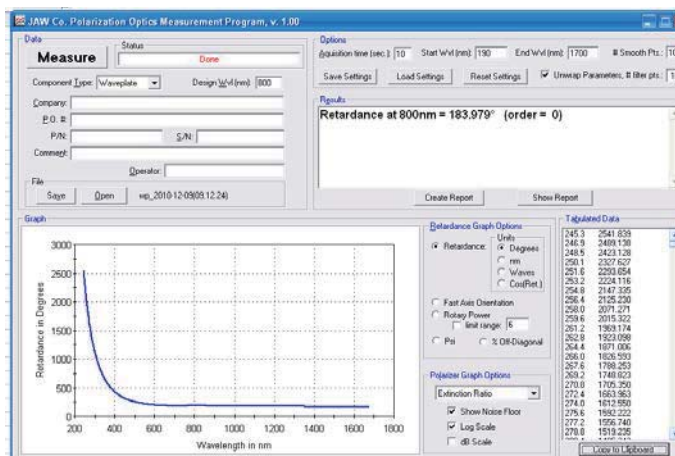

Half Waveplate

Half waveplate can be used to rotate the polarization state of a plane polarized light as shown in Figure 1.

Suppose a plane-polarized wave is normally incident on a waveplate, and the plane of polarization is at an angle θ with respect to the fast axis, as shown. After passing through the plate, the original plane wave has been rotated through an angle 2θ .

A half-wave plate is very handy in rotating the plane of polarization from a polarized laser to any other desired plane (especially if the laser is too large to rotate). Most large ion lasers are vertically polarized. To obtain horizontal polarization, simply place a half-wave plate in the beam with its fast (or slow) axis 45° to the vertical. The $\lambda/2$ plates can also change left circularly polarized light into right circularly polarized light or vice versa.

The thickness of the half waveplate is such that the phase difference is $1/2$ wavelength ($\lambda/2$, True Zero order) or certain multiple of $1/2$ wavelength [$(2n+1)\lambda/2$, multiple order].

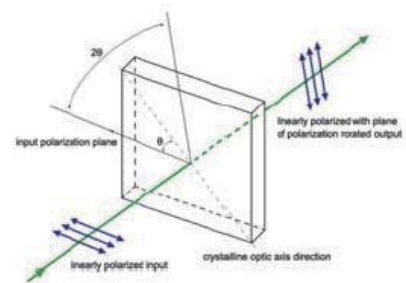

Half Waveplate

Figure 1

Quarter Waveplate

Quarter wave plate are used to turn plane-polarized light into circularly polarized light or vice versa. To do this, we must orient the wave plate so that equal amounts of fast and slow waves are excited. We may do this by orienting an incident plane-polarized wave at 45° to the fast (or slow) axis, as shown in Figure 2. When a $\lambda/4$ plate is double passed, i.e., by mirror reflection, it acts as a $\lambda/2$ plate and rotates the plane of polarization to a certain angle, i.e., 90° . This scheme is widely used in isolators, Q-switches, etc.

The thickness of the quarter waveplate is such that the phase difference is $1/4$ wavelength ($\lambda/4$, true Zero order) or certain multiple of $1/4$ wavelength [$(2n+1)\lambda/4$, multiple order].

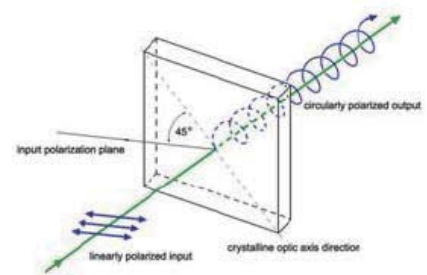

Quarter Waveplate

Figure 2

CASTECH provides many kinds of waveplates, such as Low- Order waveplate, Cemented Zero-Order waveplate, Airspaced Zero-Order waveplate, True Zero-Order waveplate, Dual wavelength waveplate and Telecom Wave Plates. Also we provide waveplates with different retardation as half-wave, quarter-wave, octadic-wave and full-wave. If you want to order the specific retardation of waveplate for your system, CASTECH is able to design any types of them for you.

High precision and mass production are available upon requirement for waveplates.

Multi-Order Waveplates

Specifications

Material:	Crystal Quartz
Diameter Tolerance:	+0/-0.25mm
Retardance Accuracy:	$< \lambda / 300$
Clear Aperture:	\geq central 90% of diameter
Surface Quality:	20-10 scratch-dig
Wavefront Distortion :	$\lambda/10@633$ nm over the clear aperture
Parallelism:	$\leq 3''$
Coating:	Laser Line AR Coating R<0.25%
Damage Threshold:	2MW/cm ² 2J/cm ² with 10 nsec Pulse

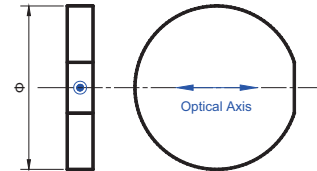

- Wide Temperature Bandwidth.
- CASTECH's standard coatings are available
- Custom designs for other sizes and coatings are also available upon request.

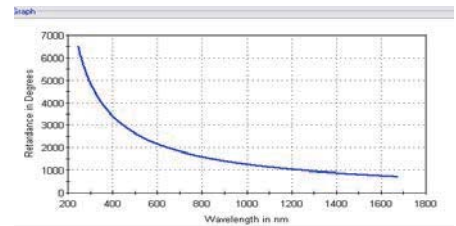

Results
Retardance at 1064nm = 90.369° (order = 3)

Single Wavelength Waveplates

Order Information

WPL — 254 — 1/4 — W1064
 Product Code $\Phi=25.4$ mm Retardation = $\lambda/4$ Design Wavelength " λ "=1064nm

Half Waveplate	Quarter Waveplate
WPL-127-1/2 - λ	WPL-127-1/4- λ
WPL-150-1/2- λ	WPL-150-1/4- λ
WPL-200-1/2- λ	WPL-200-1/4- λ
WPL-254-1/2 - λ	WPL-254-1/4- λ

Standard Wavelength (λ)

Wavelength	Wavelength	Wavelength	Wavelength	Wavelength	Wavelength
248 nm	413 nm	514.5 nm	632.8 nm	800 nm	1064 nm
266 nm	441.6 nm	532 nm	647.1 nm	830 nm	1300 nm
308 nm	457.9 nm	543.5 nm	676.4 nm	850 nm	1315 nm
351 nm	488 nm	594 nm	694.3 nm	905 nm	1320 nm
354.7 nm	510.5 nm	611.9 nm	780 nm	1050 nm	1550 nm

Dual Wavelength Waveplates

Dual wavelength waveplate is widely used on Third Harmonic Generation (THG) system. When you need a NLO crystal for type II SHG ($o+e \rightarrow e$), and a NLO crystal for type II THG ($o+e \rightarrow e$), the output polarization from SHG can not be used for THG. So you must turn the polarization to get two perpendicular polarization for type II THG. Dual wavelength waveplate works like a polarizing rotator, it can rotate the polarization of one beam and remain another beam's polarization. Also the dual wavelength waveplate can be applied to following systems:

1. Type II SHG + Type II THG
2. Type II SHG + Type I THG
3. Type I SHG + Type I THG

For example: we use KTP as SHG type II and LBO as THG type II, but the polarization of output beam from KTP is not optimized for THG type II. When we use a dual wavelength waveplate as drawing, it can change the 532nm beam to a special angle polarization but not change 1064nm beam at all.

Specifications

Material:	Crystal Quartz
Diameter Tolerance:	+0/-0.25mm
Retardance Accuracy:	$< \lambda / 100$
Clear Aperture:	\geq central 90% of diameter
Surface Quality:	20-10 scratch-dig
Wavefront Distortion :	$\lambda/10@633$ nm over the clear aperture
Parallelism:	$\leq 3''$
Coating:	Laser Line V AR Coating R<0.25%
Damage Threshold:	2MW/cm ² 2J/cm ² with 10 nsec Pulse

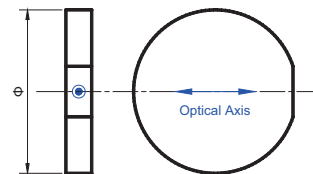
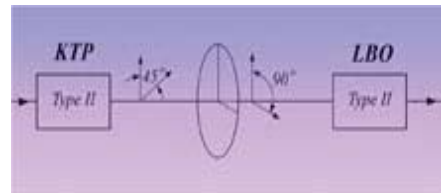

Order Information:

WPD	—	127	—	1/2	—	1/4	—	W1064	—	W532
Product Code		Φ=12.7mm		Retardation 1= $\lambda/2$		Retardation 2= $\lambda/4$		Wavelength 1=1064nm		Wavelength2=532nm

Standard Retardation

Wavelength 1-Wavelength 2	W1064-W532 (nm)	W1064-W355 (nm)	W532-W266 (nm)	W532-W355 (nm)
Retardation 1-Retardation 2	$\lambda-\lambda/2$	$\lambda/2-\lambda$	$\lambda/4-\lambda/2$	$\lambda/2-\lambda/4$

Note :

- Custom designs for other sizes ,coatings and holders are also available upon request.
- CASTECH's standard coatings are available upon request.

Optically Contacted Zero-Order Waveplates

Specifications

Material:	Crystal Quartz
Diameter Tolerance:	+0/-0.25mm
Retardance accuracy:	$< \lambda / 300$
Clear Aperture:	\geq central 90% of diameter
Surface Quality:	20-10 scratch - dig
Wavefront Distortion :	$\lambda/10@632.8$ nm over the clear aperture
Parallelism:	$\leq 3''$
Coating:	R<0.25% at design wavelength
Damage Threshold:	2MW/cm ² 2J/cm ² with 10 nsec

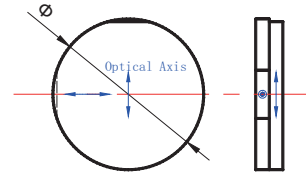

- High Damage Threshold
- Wide Temperature Bandwidth
- Broad Spectral Bandwidth

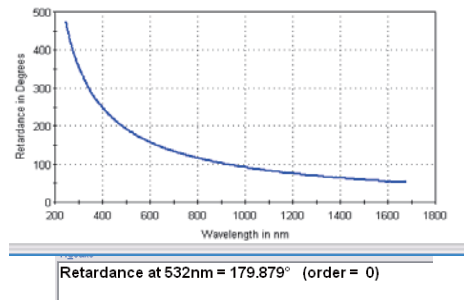

Order Information

WPZO — 127 — 1/2 — W266
 Product Code $\Phi = 12.7$ mm Retardation= $\lambda/2$ Design Wavelength " λ "=266nm

Optically Contacted Zero-Order Waveplates

Half Waveplate	Quarter Waveplate
WPZO-100-1/2- λ	WPZO-100-1/4- λ
WPZO-127-1/2- λ	WPZO-127-1/4- λ
WPZO-200-1/2- λ	WPZO-200-1/4- λ
WPZO-254-1/2- λ	WPZO-254-1/4- λ

Standard Wavelength (λ)

- Please see page 39

Note:

- Custom designs for other sizes ,coatings and holders are also available upon request.
- CASTECH's standard coatings are available.

Air Spaced Zero-Order Waveplates

Specifications

Material:	Crystal Quartz
Diameter Tolerance:	+0/-0.25mm
Retardance accuracy:	$< \lambda / 300$
Clear Aperture:	\geq central 90% of diameter
Surface Quality:	20-10 scratch - dig
Wavefront Distortion :	$\lambda/10@632.8$ nm over the clear aperture
Parallelism:	$\leq 3''$
AR Coating:	R<0.25% per surface at design wavelength
Damage Threshold:	2MW/cm ² 2J/cm ² with 10 nsec

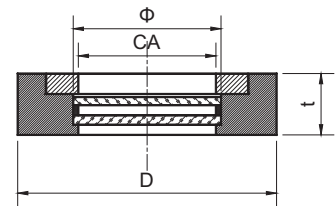

- High Damage Threshold
- Wide Temperature Bandwidth
- Broad Spectral Bandwidth
- CASTECH's standard coatings are available
- Custom designs for other sizes and coatings are also available upon request

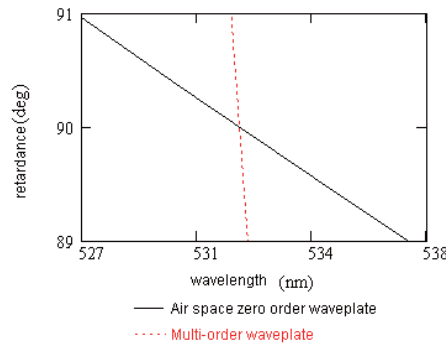
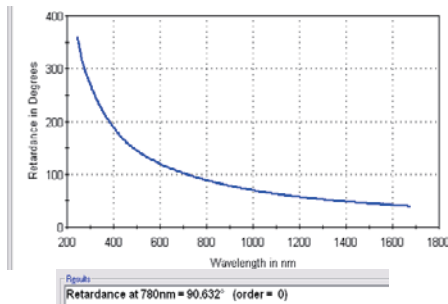

Order Information

WPZA — 127 — 1/2 — W266
 Product Code $\Phi = 12.7$ mm Retardance = $\lambda/2$ Design Wavelength " λ " = 266nm

Air Spaced Zero-Order Waveplates

Half Waveplate	Quarter Waveplate
WPZA-100-1/2- λ	WPZA-100-1/4- λ
WPZA-127-1/2- λ	WPZA-127-1/4- λ
WPZA-200-1/2- λ	WPZA-200-1/4- λ
WPZA-254-1/2- λ	WPZA-254-1/4- λ

- Standard Wavelength ,please see page 39.
- Standard Mounts and Holders ,please see page 48.

True Cemented Zero-Order Waveplates

Specifications

Material:	Crystal Quartz
Substrate Material:	BK7
Diameter Tolerance:	+0/-0.2mm
Clear Aperture:	≥ central 90% of diameter
Retardance Accuracy:	$< \lambda / 300$
Surface Quality:	20-10 scratch - dig
Wavefront Distortion	$\lambda/8@632.8$ nm over the clear aperture
Parallelism:	$\leq 10''$
AR Coating:	R<0.25% at design wavelength
Damage Threshold	500W/cm ² 4J/cm ² with 20 nsec

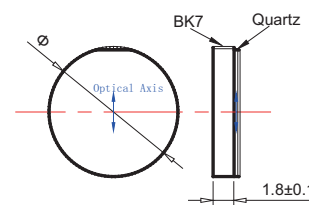

Order Information

WPCT — 127 — 1/4 — W532
 Product Code $\Phi = 12.7$ mm Retardance= $\lambda/4$ Design Wavelength " λ "=532nm

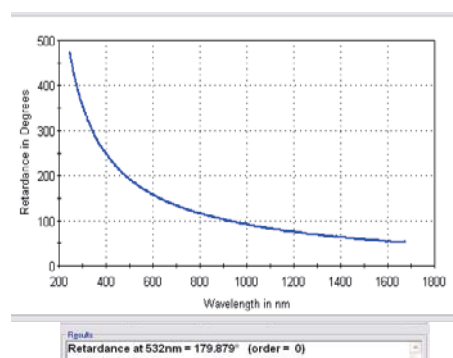
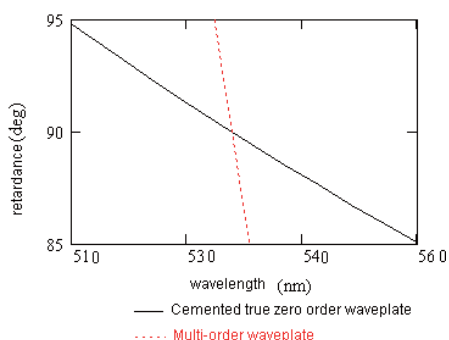

Cemented True Zero-Order Waveplates

Half Waveplate	Quarter Waveplate
WPCT-100-1/2- λ	WPCT-100-1/4- λ
WPCT-127-1/2- λ	WPCT-127-1/4- λ
WPCT-200-1/2- λ	WPCT-200-1/4- λ
WPCT-254-1/2- λ	WPCT-254-1/4- λ

Note:

- Custom designs for other sizes and coatings are also available upon request.
- CASTECH's standard coatings are available.

True Zero-Order Waveplates

Specifications

Material:	Crystal Quartz
Diameter Tolerance:	+0/-0.2mm
Retardance Accuracy:	$< \lambda / 300$
Clear Aperture:	\geq central 90% of diameter
Surface Quality:	20-10 scratch - dig
Wavefront Distortion :	$\lambda/8@632.8$ nm over the clear aperture
Parallelism:	$\leq 10''$
Coating:	R<0.25% per surface at design wavelength
Damage Threshold:	500W/cm ² 4J/cm ² with 20 nsec

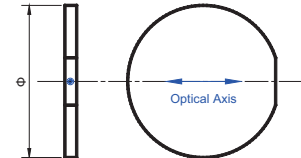

Order Information

WPT — 127 — 1/4 — W532
 Product Code $\Phi = 12.7$ mm Retardation= $\lambda/4$ Design Wavelength" λ "=532nm

True Zero-Order Waveplates

Half Waveplate	Quarter Waveplate
WPT-100-1/2- λ	WPT-100-1/4- λ
WPT-127-1/2- λ	WPT-127-1/4- λ
WPT-200-1/2- λ	WPT-200-1/4- λ
WPT-254-1/2- λ	WPT-254-1/4- λ

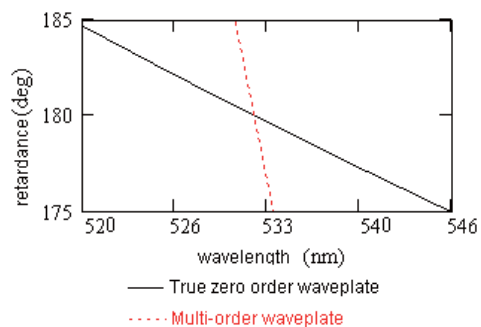
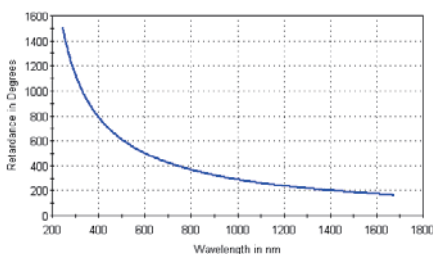

Note:

- Custom designs for other sizes, coatings and holder are also available upon request.
- CASTECH's standard coatings are available.

Achromatic Zero-Order Waveplates

Achromatic Zero-Order waveplate is made from two different substrate Material such as crystal quartz and magnesium fluoride. For the single material waveplates the working wavelength is very limited because of the dispersion of the material. While Achromatic Zero-Order Waveplate use two different kinds of material, the dispersions of the birefringence are also different. Hence such waveplate is not sensitive to the wavelength change.

CASTECH design Achromatic Zero-Order Quartz-MgF2 waveplates with working wavelength range larger than 300nm and retardation accuracy better than $\lambda/50$ for $\lambda/2$ waveplate and better than $\lambda/100$ for $\lambda/4$ waveplate.

Main advantages:

- Extremely broad wavelength ranges
- High damage threshold for Air-spaced Achromatic Zero-Order waveplate
- Low sensitivity within the designed wavelength
- Retardation tolerance up to $\lambda/100$ over the wavelength range

CASTECH can offer two kinds of Achromatic Zero-Order Waveplates:

Air Spaced and Optically Contacted Achromatic Zero-Order Waveplates

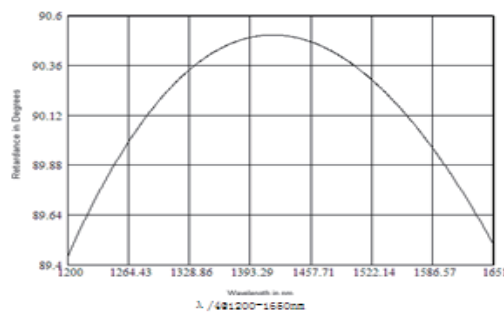
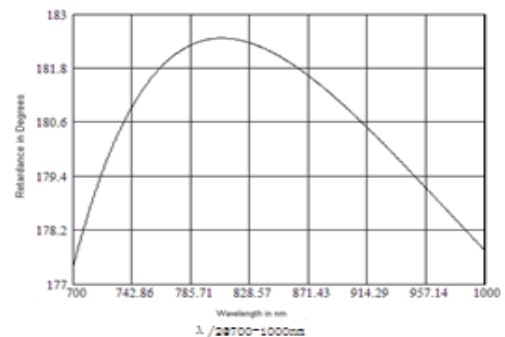
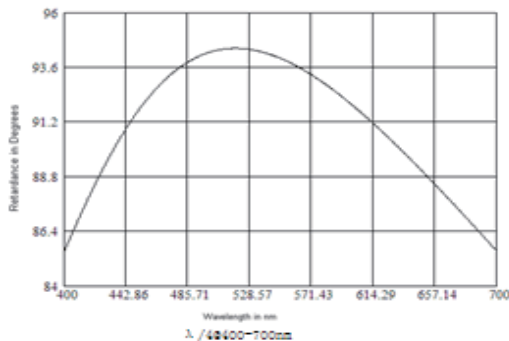

Achromatic Zero-Order Waveplates

Specifications

Material:	Crystal Quartz and Magnesium Fluoride
Diameter Tolerance:	+0/-0.2mm
Retardance Accuracy:	better than $\lambda/50$ for $\lambda/2$ achromatic waveplates better than $\lambda/100$ for $\lambda/4$ achromatic waveplates
Clear Aperture:	\geq central 90% of diameter
Surface Quality:	40/20 scratch / dig
Wavefront Distortion :	$\lambda/4@632.8$ nm over the clear aperture
Parallelism:	$\leq 10''$
Coating:	AR coating at design wavelength
Damage Threshold:	500W/cm ² 4J/cm ² with 20 nsec

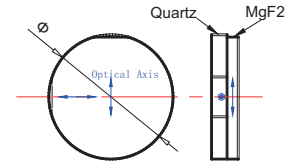

Optically Contacted
Achromatic Zero-Order Waveplate

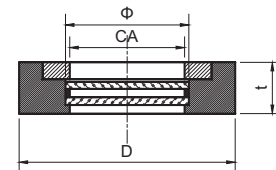

Air-Spaced
Achromatic Zero-Order Waveplate

Order Information

WPAO	—	127	—	1/4	—	W400-700
Product Code		$\Phi = 12.7$ mm		Retardance = $\lambda/4$		Design Wavelength “ λ ” = 400-700nm

Achromatic Zero-Order Waveplates

Optically Contacted Achromatic Zero-Order Waveplate		Air-Spaced Achromatic Zero-Order Waveplate	
Half Achromatic Waveplate	Quarter Achromatic Waveplate	Half Achromatic Waveplate	Quarter Achromatic Waveplate
WPAO-127-1/2- λ	WPAO-127-1/4- λ	WPAA-127-1/2- λ	WPAA-127-1/4- λ
WPAO-150-1/2- λ	WPAO-150-1/4- λ	WPAA-150-1/2- λ	WPAA-150-1/4- λ
WPAO-200-1/2- λ	WPAO-200-1/4- λ	WPAA-200-1/2- λ	WPAA-200-1/4- λ
WPAO-254-1/2- λ	WPAO-254-1/4- λ	WPAA-254-1/2- λ	WPAA-254-1/4- λ

Standard Wavelength Ranges(λ)

400-700 nm	700-1000 nm	1200-1650 nm
------------	-------------	--------------

Note:

- Custom designs for other sizes and coatings are also available upon request.
- CASTECH's standard coatings are available.
- Other waveplates with different wavelength range (between 400-2100nm) are also available upon request, please contact CAETECH for more information.

Telecom Waveplates

Specifications

Material:	Crystal Quartz
Diameter Tolerance:	+0/-0.1mm
Design Wavelength:	1550nm
Retardance Accuracy:	better than $\lambda/300@1550\text{nm}$
Surface Quality:	40/20 scratch / dig
Wavefront Distortion :	$\lambda/4@632.8\text{ nm}$ over the full aperture
Parallelism:	$\leq 3''$
AR Coating:	Both surfaces $R < 0.25\% @ 1525 - 1565\text{ nm}$
Damage Threshold:	500W/cm ² 4J/cm ² with 20 nsec

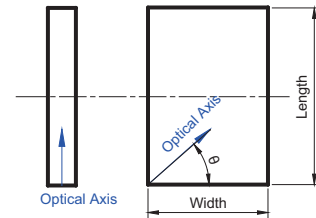

Telecom Waveplates

Order Information

WPT —
 040 —
 030 —
 1/4 —
 W1550
 Product Code Length=4.0 mm Width=3.0mm Retardance= $\lambda/4$ Design Wavelength " λ "=1550nm

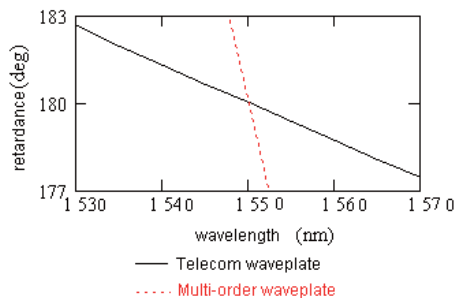

Types:

"1/4" means Quarter Waveplate
 "1/2" means Half Waveplate

Also, please provide the angle θ .

Telecom waveplates are designed and manufactured specifically to meet the demanding requirements of telecom component designers.

CASTECH provides telecom waveplate with many kinds of sizes, they are 91.5 μm thick for the half-waveplate and 45.7 μm thick for the quarter-waveplate at 1550nm. The telecom waveplates are AR coated from 1525nm to 1565nm in order to minimize surface reflection losses.

Standard Telecom Waveplates

size	Design Wavelength	AR Coating	Retardation
Kinds of size	1550 nm	$R < 0.25\% @ 1525 - 1565\text{ nm}$	$\lambda/4$ or $\lambda/2$

Note:

- Custom designs for other specifications and coating are also available upon request.

Mounts and Holders for Waveplates

Ring Mount

Material and finished:	Black anodized aluminum
Outside Diameter(D) Tolerance:	± 0.1mm
Thickness (t) Tolerance:	± 0.1mm
Waveplate Diameter (Ø) Tolerance:	+0.15,-0.0mm

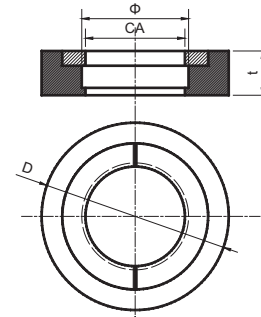

Part No.	D (mm)	Ø (mm)	Clear Aperture (mm)	Thickness (mm)
RM-01	25.4	10.0	9.0	6.0
RM-02	25.4	12.7	11.5	6.0
RM-03	25.4	15.0	13.5	6.0
RM-04	30.0	20.0	18.0	6.0
RM-05	30.0	25.4	22.8	6.0

Rotating Holder

Material and finished:	Black anodized aluminum
Rotation Accuracy:	1°
Dimension Tolerance:	± 0.1mm

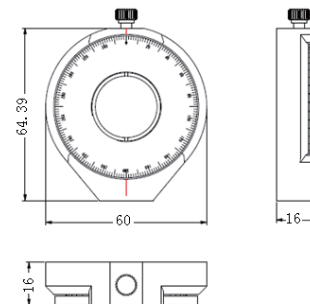

Order Information

Part No.	Outside Dimension (mm)			Installation Dimension (mm)		Matched Screw Diameter (mm)
	Matched Screw Diameter	Height	Length	Diameter	Thickness	
RH-01	64.39	60.0	16.0	25.4	6.0	6.35
RH-02	64.39	60.0	16.0	30.0	6.0	6.35

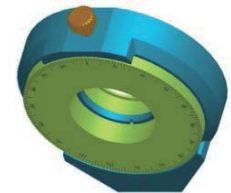

- Custom designs for other sizes of mount are also available.

Polarization Rotator

Specifications

Material:	Crystal Quartz
Dimension Tolerance:	+0.0, -0.1mm
Wavefront Distortion:	$< \lambda / 8 @ 632.8\text{nm}$
Wavelength Range:	440-1600nm
Rotation Accuracy:	< 5 arc min
Surface Quality:	20/10 scratch /dig
Clear Aperture:	>central 90% of diameter
AR Coating:	R<0.25% per surface at central wavelength
Rotation Orientation:	Clockwise (right-handed, standard)

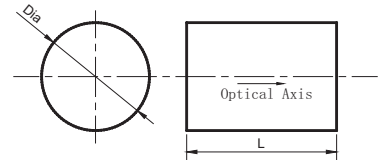

- Excellent optical performance
- All kinds of coatings are available
- Custom designs for other sizes and coatings are also available upon request
- Left-handed polarization rotator is also available

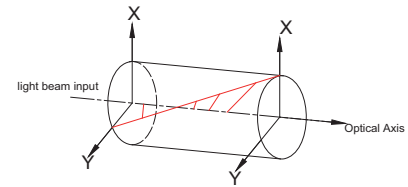

Order Information

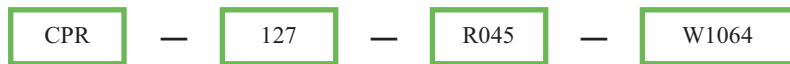

Product Code Diameter=12.7 (mm) Rotation =45 ° Design Wavelength “λ”=1064nm

For example: CPR127-R045-W1064 is a diameter 12.7mm , 45 ° rotation@1064nm ,Polarizing Rotator

Polarizing Rotator

Part Number	Diameter (mm)	Rotation (Clockwise)
CPR-127-R045-λ	12.7	45 °
CPR-150-R045-λ	15.0	45 °
CPR-200-R045-λ	20.0	45 °
CPR-254-R045-λ	25.4	45 °
CPR-127-R090-λ	12.7	90 °
CPR-150-R090-λ	15.0	90 °
CPR-200-R090-λ	20.0	90 °
CPR-254-R090-λ	25.4	90 °

Standard Wavelength(λ)

532 nm	632.8 nm	1064 nm
--------	----------	---------

Glan-Laser Polarizer

Specifications

Wavelength Range:	Calcite: 350-2300 nm; α -BBO: 190-3500 nm
Extinction Ratio:	Calcite: $<5 \times 10^{-5}$; α -BBO: $<5 \times 10^{-6}$;
Surface Quality:	60/40 Scratch / Dig
Dimension Tolerance:	± 0.1 mm
Beam Deviation:	< 3 arc min
Wavefront Distortion:	$< \lambda / 4$ @632.8nm for α -BBO $< \lambda / 2$ @632.8nm for Calcite
Coating:	Single layer MgF ₂
Damage Threshold:	>500 MW/cm ²
Housing:	Black Anodized Aluminum

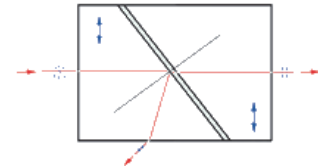
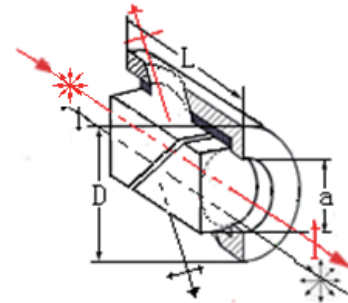

- High Polarization Purity
- Wide Wavelength Range
- High UV Transmission
- Available with two, one or no escape ports for extra power capacity
- Suitable for high power applications

Order Information

PGL	—	100	—	CAL
Product Code		Clear Aperture a=10mm		Material Code Calcite

Glan-Laser Polarizer

Part Number	Wavelength Range (nm)	a (mm)	D (mm)	L ± 0.1 (mm)	Material
PGL-100-CAL	350-2300	10	25.4	26.2	Calcite
PGL-150-CAL		15	30	33.3	Calcite
PGL-100-ABBO1	200-270	10	25.4	31.0	α -BBO
PGL-150-ABBO1		15	30	38.6	α -BBO
PGL-100-ABBO2	400-700	10	25.4	26.0	α -BBO
PGL-150-ABBO2		15	30	33.4	α -BBO
PGL-100-ABBO3	700-3000	10	25.4	25.9	α -BBO
PGL-150-ABBO3		15	30	33.0	α -BBO

Note:

- Custom designs for other sizes and coatings are also available upon request.
- **YVO4 Glan-Laser Polarizer** is also available upon request.

Glan-Thompson Polarizer

Specifications

Material:	Calcite ; α -BBO
Wavelength Range:	Calcite: 350-2300 nm α -BBO: 220-900nm
Extinction Ratio:	Calcite: $<5 \times 10^{-5}$ α -BBO: $<5 \times 10^{-6}$
Surface Quality:	60/40 Scratch / Dig
Dimension Tolerance:	± 0.1 mm
Damage Threshold:	>200 MW/cm ²
Beam Deviation:	< 3 arc min
Wavefront Distortion:	$< \lambda / 4$ @632.8nm
Coating:	Single layer MgF ₂
Housing:	Black Anodized Aluminum

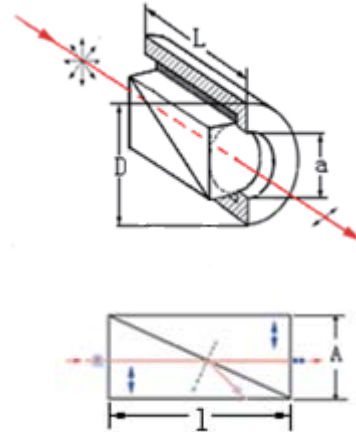

- Large Acceptance Angle: Special design for the ratio of L/A (length/aperture) guarantees the wide acceptance angle
- High Polarization Purity
- Suitable for low power applications

Order Information

PGM	—	080	—	ABBO
Product Code		Clear Aperture a=8mm		Material Code α -BBO

Glan-Thompson Polarizer

Part Number	L/A	Wavelength Range	a (mm)	D (mm)	L ± 0.1 (mm)	Material
PGM-080-CAL-2.5	2.5	350-2300	8	25.4	28	Calcite
PGM-100-CAL-2.5			10	25.4	33	Calcite
PGM-150-CAL-2.5			15	30	45.5	Calcite
PGM-080-CAL-3.0	3	350-2300	8	25.4	32	Calcite
PGM-100-CAL-3.0			10	25.4	38	Calcite
PGM-150-CAL-3.0			15	30	53	Calcite
PGM-080-ABBO-1.6	1.6	220-900	8	25.4	21	α -BBO
PGM-100-ABBO-1.6			10	25.4	24.5	α -BBO
PGM-150-ABBO-1.6			15	30	32.5	α -BBO

Note :

- Custom designs for other sizes and coatings are also available upon request.

Wollaston Polarizer

Specifications

Material:	Calcite; α -BBO; YVO ₄ ; Quartz
Wavelength Range:	Calcite: 350-2300 nm α -BBO: 220-900nm YVO ₄ : 400-4000nm Quartz: 200-2300nm
Extinction Ratio:	Calcite, Quartz: $<5 \times 10^{-5}$ α -BBO, YVO ₄ : $<5 \times 10^{-6}$
Surface Quality:	60/40 Scratch / Dig
Dimension Tolerance:	± 0.1 mm
Damage Threshold:	>500 MW/cm ²
Beam Deviation:	< 3 arc min
Wavefront Distortion:	$< \lambda / 4$ @632.8nm
Coating	Single layer MgF ₂
Housing	Black Anodized Aluminum

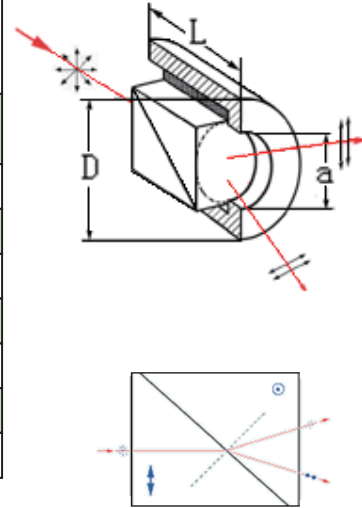

- Wide Wavelength Range
- Both ordinary and extraordinary beams are deviated
- Suitable for low power application and where the large deviations is required

Order Information

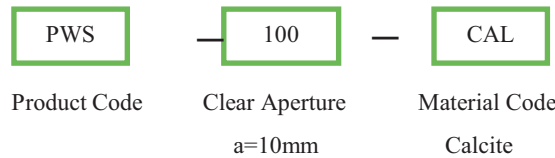

Wollaston Polarizer

Part Number	Separation Angle(°)	a (mm)	D (mm)	Material
PWS-100-CAL	16.7-22.5	10	25.4	Calcite
PWS-150-CAL		15	30	Calcite
PWS-100-ABBO	15-27	10	25.4	α -BBO
PWS-150-ABBO		15	30	α -BBO
PWS-100-QZ	2-3	10	25.4	Quartz
PWS-150-QZ		15	30	Quartz
PWS-100-YVO ₄	19.6-23.3	10	25.4	YVO ₄
PWS-150-YVO ₄		15	30	YVO ₄

Note:

- Custom designs for other sizes and coatings are also available upon request.

Rochon Polarizer

Specifications

Material:	α -BBO; YVO ₄ ; Quartz
Wavelength Range:	α -BBO: 220-900nm YVO ₄ : 400-4000nm Quartz: 200-2300nm
Extinction Ratio:	Quartz: $<5 \times 10^{-5}$ α -BBO, YVO ₄ : $<5 \times 10^{-6}$
Surface Quality:	60/40 Scratch / Dig
Dimension Tolerance:	± 0.1 mm
Damage Threshold:	>500 MW/cm ²
Beam Deviation:	< 3 arc min
Wavefront Distortion:	$< \lambda / 4$ @632.8nm
Coating	Single layer MgF ₂
Housing	Black Anodized Aluminum

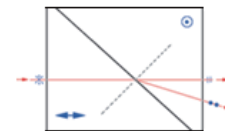
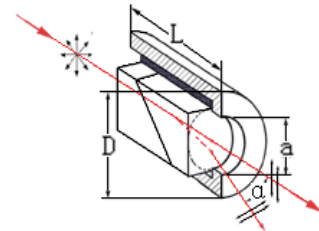

- Wide Wavelength Range
- Large Field Angle
- High Extinction Ratio
- Guarantee a wide transmission range, especially, suitable for UV applications
- Split the ordinary and extraordinary ray, but only extraordinary beam is deviated

Order Information

PRC	—	080	—	ABBO
Product Code		Clear Aperture		Material
		a=8mm		

Rochon Polarizer

Part Number	Separation Angle(°)	a (mm)	D (mm)	Material
PRC-080-ABBO	8.0-14	8	25.4	α -BBO
PRC-100-ABBO		10	25.4	α -BBO
PRC-150-ABBO		15	30	α -BBO
PRC-080-QZ	1.0-1.5	8	25.4	Quartz
PRC-100-QZ		10	25.4	Quartz
PRC-150-QZ		15	30	Quartz
PRC-080-YVO4	9.8-13.0	8	25.4	YVO4
PRC-100-YVO4		10	25.4	YVO4
RCP-150-YVO4		15	30	YVO4

Note:

- Custom designs for other sizes and coatings are also available upon request.

Broadband Polarization Beamsplitter Cubes

Specifications

Material:	SF2
Dimension Tolerance:	± 0.25mm
Surface Quality:	40/20 scratch / dig
Wavefront Distortion:	$\lambda/4@6328\text{nm}$ over the clear aperture
Clear Aperture:	>central 80% of diameter
Transmitted Beam Deviation:	<5 arc min
Reflected Beam Deviation:	90° ± 5 arc min
Efficiency:	$T_p > 80\%$ min, >90% average, $R_s > 99.5\%$ average
Extinction Ratio:	$T_p:T_s > 500:1$, 1000:1 average
Antireflective Coating:	Broadband multilayer coating: $R_{\text{avg}} < 1\%$ per surface
Chamfers:	<0.5mm face width × 45° typical
Damage Threshold:	2KW/cm ² , 1J/cm ² with 10nsec pulses typical

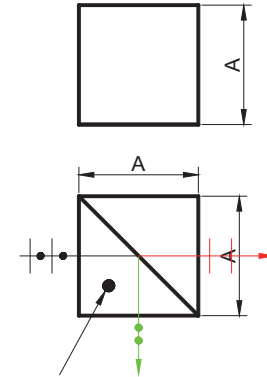

NOTE: To avoid damage, a dot placed on the side indicating beam must enter prism.

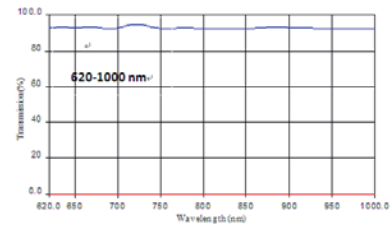
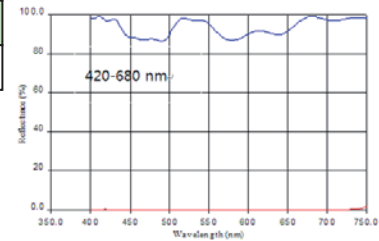

Order Information

BPBC — 127 — W420-680

Product Code Dimension "A"=12.7mm Wavelength Range
"λ"=420-680 nm

Broadband Polarization Beamsplitter Cubes

Part Number	Dimension A (mm)
BPBC-063-λ	6.35
BPBC-127-λ	12.7
BPBC-150-λ	15.0
BPBC-200-λ	20.0
BPBC-254-λ	25.4

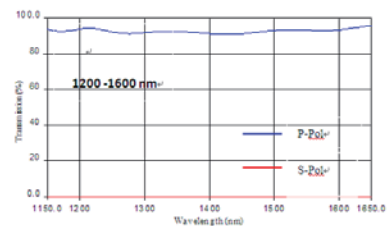
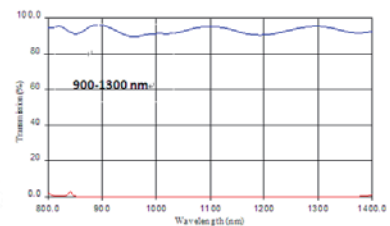
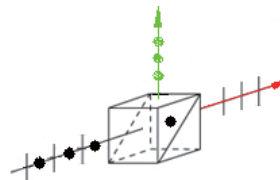

Standard Wavelength Range(λ)

420-680 nm	620-1000 nm	900-1300nm	1200-1600 nm
------------	-------------	------------	--------------

Note:

- Custom designs for other sizes and coatings are also available upon request.

UV Laser Line Polarization Beamsplitter Cubes

Specifications

Material:	UV fused silica
Dimension Tolerance:	± 0.25mm
Surface Quality:	40/20 scratch / dig
Wavefront Distortion:	$\lambda/4@632.8\text{nm}$ over the clear aperture
Clear Aperture:	>central 80% of diameter
Transmitted Beam Deviation:	<5 arc min
Reflected Beam Deviation:	90° ± 5 arc min
Efficiency:	$T_p > 90\%$, $R_s > 99\%$
Extinction Ratio:	$T_p : T_s > 100:1$
Antireflective Coating:	Multilayer coating : $R_{\text{avg}} < 0.25\%$ per surface
Chamfers:	<0.5mm face width × 45° typical
Damage Threshold:	100 W/cm ² , 0.1J/cm ² with 10nsec pulses typical

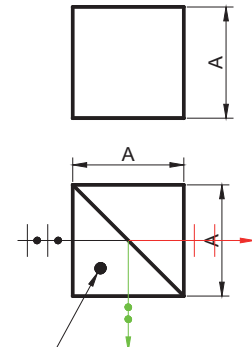

NOTE: To avoid damage, a dot placed on the side indicating beam must enter prism.

Order Information



Product Code Dimension "A" = 12.7mm Wavelength "λ" = 248nm

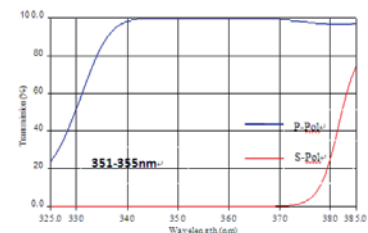
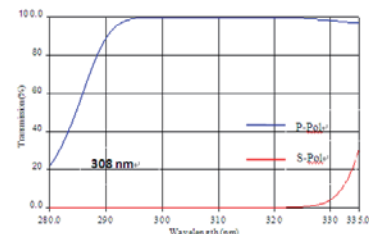
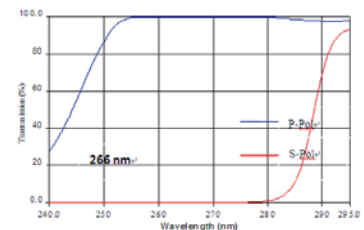
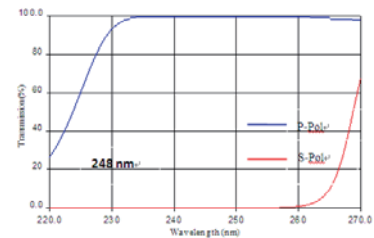

UV Laser Line Polarization Beamsplitter Cubes

Part Number	Dimension A (mm)
UPBC-063-λ	6.35
UPBC-127-λ	12.7
UPBC-150-λ	15.0
UPBC-200-λ	20.0
UPBC-254-λ	25.4

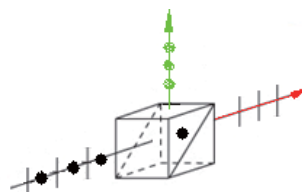

Standard Wavelength(λ)

248 nm	266 nm	308 nm	351-355 nm
--------	--------	--------	------------

Note:

- Custom designs for other sizes and coatings are also available upon request.

Laser Line Polarization Beamsplitter Cubes

Specifications

Material:	BK7
Dimension Tolerance:	$\pm 0.25\text{mm}$
Surface Quality:	40/20 scratch / dig
Wavefront Distortion:	$\lambda/4@632.8\text{nm}$ over the clear aperture
Clear Aperture:	>central 80% of diameter
Transmitted Beam Deviation:	<5 arc min
Reflected Beam Deviation:	$90^\circ \pm 5$ arc min
Efficiency:	$T_p > 95\%$, $R_s > 99.8\%$
Extinction Ratio:	$T_p:T_s > 100:1$
Antireflective Coating:	Multilayer coating : $R_{\text{avg}} < 0.25\%$ per surface
Chamfers:	<0.5mm face width $\times 45^\circ$ typical
Damage Threshold:	2KW/cm ² , 1J/cm ² with 10nsec pulses typical

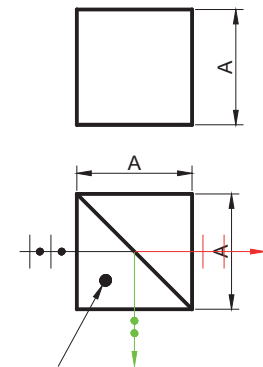
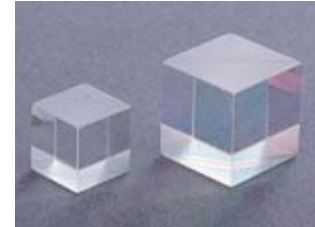

NOTE: To avoid damage, a dot placed on the side indicating beam must enter prism.

Order Information

PBC — 127 — W1064

Product Code Dimension "A"= 12.7mm Wavelength " λ "=1064nm

Laser Line Polarization Beamsplitter Cubes

Part Number	Dimension A (mm)
PBC-063- λ	6.35
PBC-127- λ	12.7
PBC-150- λ	15.0
PBC-200- λ	20.0
PBC-254- λ	25.4

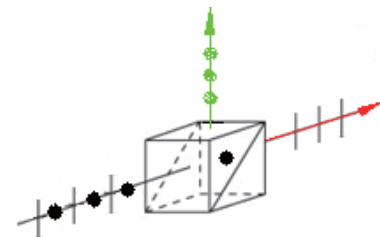
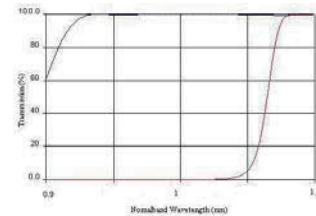

Standard Wavelength(λ)

441-458 nm	488-514.5 nm	532 nm	632.8 nm	670 nm
780 nm	830 nm	1064 nm	1300 nm	1550 nm

Broadband Dielectric Beamsplitters

Specifications

Material:	BK7 or UV fused silica
Dimension Tolerance:	+0/-0.13mm
Thickness Tolerance:	±0.38 mm
Wedge:	30±15 arc min
Wavefront Distortion:	$\lambda/10@632.8\text{nm}$ over the clear aperture
Clear Aperture:	>Central 80% of diameter
S1 Beamsplitter Coating:	$R_s=50\% \pm 5\%$, $R_p \leq R_s @ 45^\circ$ incidence
S2 AR Coating:	Multilayer coating: $R_{avg} < 0.75\% @ 45^\circ$ incidence
Chamfers:	25.4mm:0.25-0.76 mm face width x $45^\circ \pm 15^\circ$ 50.8 mm:0.38-1.14 mm face width x $45^\circ \pm 15^\circ$
Damage Threshold:	500W/cm ² , 1J/cm ² with 10 nsec pulses

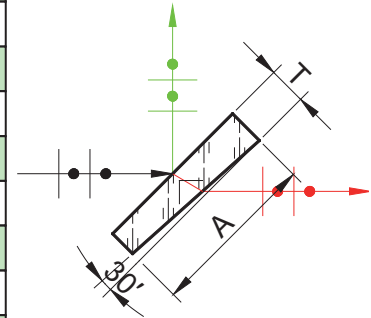

NOTE: Mark beamsplitter surface with an arrow on the side

Order Information

BBS — 127 — 061 — W400-700 — BK7

Product Code Dimension "A"= 12.7mm Thickness=6.1mm Wavelength "λ"=400-700nm Material

Broadband Dielectric Beamsplitters

Part number	Diameter A (mm)	Thickness T (mm)	Material
BBS-127-031-λ-BK7	12.7	3.1	BK7
BBS-254-061-λ-BK7	25.4	6.1	BK7
BBS-50.8-094-λ-BK7	50.8	9.4	BK7
BBS-127-031-λ-UVFS	12.7	3.1	UVFS
BBS-254-061-λ-UVFS	25.4	6.1	UVFS
BBS-508-094-λ-UVFS	50.8	9.4	UVFS

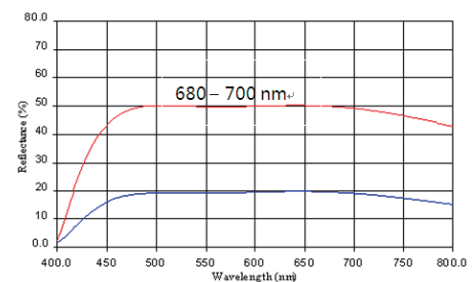

Standard Wavelength Range(λ)

480-700 nm	700-950 nm	1290-1580 nm
------------	------------	--------------

Laser Line Non-Polarizing Beamsplitters

Specifications

Material:	BK7
Dimension Tolerance:	+0/-0.13mm
Surface Quality:	20/10 scratch / dig
Thickness :	6.1 ± 0.38mm
Wedge:	30 ± 15 arc min
Wavefront Distortion:	$\lambda/10@632.8\text{nm}$ over the clear aperture
Clear Aperture:	>Central 80% of diameter
Angle of Incidence :	45° ± 3°
Transmission:	50% ± 5%, independent of polarization
Reflection:	50% ± 5% independent of polarization
Polarization:	P- and S-polarization components matched to within 5%
Absorbition:	<0.5%
Antireflective & Coating	Multilayer coating: $R_{\text{avg}} < 0.5\% @ 45^\circ$ incidence
Damage Threshold:	500W/cm ² , 0.5J/cm ² with 10nsec pulses

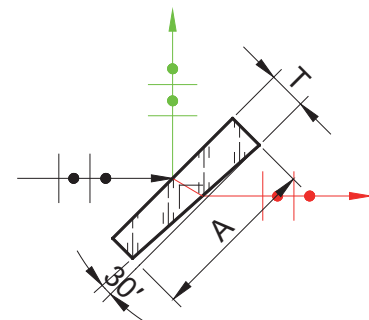

NOTE: Mark beamsplitter surface with an arrow on the side

Polarization components matched to within 5%

Virtually zero absorption for true 50/50 beamsplitting

Order Information

BSNP — 254 — 061 — W1064

Product Code Dimension "A" = 25.4mm Thickness = 6.1mm Wavelength "λ" = 1064nm

Standard Wavelength (nm):

441.6 nm	488 nm	514.5 nm	532 nm	632.8 nm	1550 nm
670 nm	780 nm	830 nm	1064 nm	1300 nm	

Laser Line Non-Polarization Beamsplitters

Part number	Diameter A (mm)	Thickness T (mm)	Material
BSNP-127-031-λ	12.7	3.1	BK7
BSNP-254-061-λ	25.4	6.1	BK7
BSNP-508-094-λ	50.8	9.4	BK7

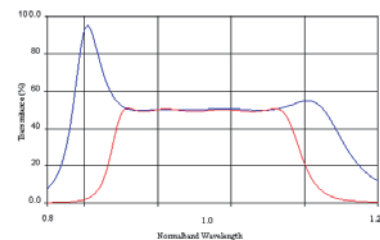

UV Non-Polarization Beamsplitter Cubes

Specifications

Material:	UV fused silica
Dimension Tolerance:	$\pm 0.25\text{mm}$
Surface Quality:	40/20 scratch / dig
Wavefront Distortion:	$\lambda/4@632.8\text{nm}$ over the clear aperture
Clear Aperture:	>Central 80% of diameter
Transmitted Beam Deviation:	<5 arc min
Reflected Beam Deviation:	$90^\circ \pm 5^\circ$ arc min
Transmission:	$50 \pm 3\%$, independent of polarization
Reflection:	$50 \pm 3\%$, independent of polarization
Polarization:	$ T_s - T_p \leq 15\%$ and $ R_s - R_p \leq 15\%$
Antireflection Coating:	Multilayer coating : $R_{\text{avg}} < 0.5\%$ per surface
Chamfers:	<0.5mm face width $\times 45^\circ$ typical
Damage Threshold:	1 KW/cm ² , 0.5J/cm ² with 10 nsec pulses, typical

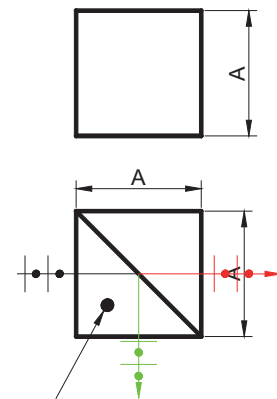
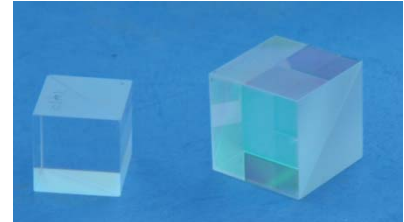

NOTE: To avoid damage, a dot placed on the side indicating beam must enter prism.

Order Information

UNPBC — 127 — W325

Product Code Dimension "A" = 12.7mm Design Wavelength
"λ" = 325 nm

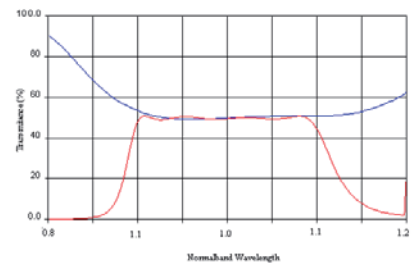

UV Non-Polarization Beamsplitter Cubes

Part number	Dimension A (mm)
UNPBC-063-λ	6.35
UNPBC-127-λ	12.7
UNPBC-150-λ	15.0
UNPBC-200-λ	20.0
UNPBC-254-λ	25.4

Standard Wavelength(λ)

325 nm	337.1 nm	355 nm	365 nm
--------	----------	--------	--------

Laser Line Non-Polarization Beamsplitter Cubes

Specifications

Material:	BK7
Dimension Tolerance:	± 0.25mm
Surface Quality:	40/20 scratch / dig
Wavefront Distortion:	$\lambda/4@6328\text{nm}$ over the clear aperture
Clear Aperture:	Central diameter, >80% of dimension
Transmitted Beam Deviation:	<5 arc min
Reflected Beam Deviation:	90° ± 5° arc min
Transmission:	50 ± 3%, independent of polarization 5° arc min
Reflection:	50 ± 3%, independent of polarization
Polarization:	$ T_s - T_p \leq 3\%$ and $ R_s - R_p \leq 3\%$
Antireflection Coating:	Multilayer coating : $R_{\text{avg}} < 0.5\%$ per surface
Chamfers:	<0.5mm face width × 45° typical
Damage Threshold:	2KW/cm ² , 1J/cm ² with 10nsec pulses typical

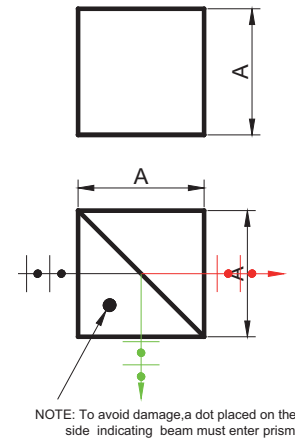

Order Information

NPBC — 127 — W1064

Product Code Dimension "A"=12.7mm Design Wavelength
"λ"=1064 nm

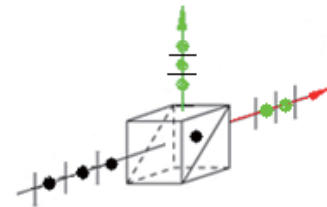

Laser Line Non-Polarization Beamsplitter Cubes

Part number	Dimension A (mm)
NPBC-063-λ	6.35
NPBC-127-λ	12.7
NPBC-150-λ	15.0
NPBC-200-λ	20.0
NPBC-254-λ	25.4

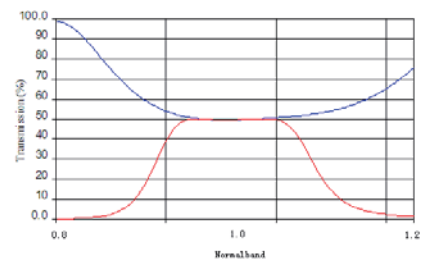

Standard Wavelength(λ)

441.6 nm	488-514.5 nm	532 nm	632.8 nm	670 nm
780 nm	830 nm	1064 nm	1300 nm	1550 nm



福建福晶科技股份有限公司
CASTECH INC.

ADD: Building No.9, Zone F, 89 Ruan
jian Avenue, Fuzhou, Fujian
350003, China

TEL: +86-591-83710533

FAX: +86-591-83711593

E-mail: SALES@CASTECH.COM

WWW.CASTECH.COM
WWW.CASTECH.COM